



# **M37760T-RPD-E**

---

Emulation Pod for 7760 Group 7760/7762/776A MCUs (for PC4701 Emulator System)

## **User's Manual**

\* IC61-1004-051 is a product of Yamaichi Electronics Co., Ltd.

### **Keep safety first in your circuit designs!**

- Renesas Technology Corporation and Renesas Solutions Corporation put the maximum effort into making semiconductor products better and more reliable, but there is always the possibility that trouble may occur with them. Trouble with semiconductors may lead to personal injury, fire or property damage. Remember to give due consideration to safety when making your circuit designs, with appropriate measures such as (i) placement of substitutive, auxiliary circuits, (ii) use of nonflammable material or (iii) prevention against any malfunction or mishap.

### **Notes regarding these materials**

- These materials are intended as a reference to assist our customers in the selection of the Renesas Technology product best suited to the customer's application; they do not convey any license under any intellectual property rights, or any other rights, belonging to Renesas Technology Corporation, Renesas Solutions Corporation or a third party.
- Renesas Technology Corporation and Renesas Solutions Corporation assume no responsibility for any damage, or infringement of any third-party's rights, originating in the use of any product data, diagrams, charts, programs, algorithms, or circuit application examples contained in these materials.
- All information contained in these materials, including product data, diagrams, charts, programs and algorithms represents information on products at the time of publication of these materials, and are subject to change by Renesas Technology Corporation and Renesas Solutions Corporation without notice due to product improvements or other reasons. It is therefore recommended that customers contact Renesas Technology Corporation, Renesas Solutions Corporation or an authorized Renesas Technology product distributor for the latest product information before purchasing a product listed herein. The information described here may contain technical inaccuracies or typographical errors. Renesas Technology Corporation and Renesas Solutions Corporation assume no responsibility for any damage, liability, or other loss rising from these inaccuracies or errors. Please also pay attention to information published by Renesas Technology Corporation and Renesas Solutions Corporation by various means, including the Renesas home page (<http://www.renesas.com>).
- When using any or all of the information contained in these materials, including product data, diagrams, charts, programs, and algorithms, please be sure to evaluate all information as a total system before making a final decision on the applicability of the information and products. Renesas Technology Corporation and Renesas Solutions Corporation assume no responsibility for any damage, liability or other loss resulting from the information contained herein.
- Renesas Technology semiconductors are not designed or manufactured for use in a device or system that is used under circumstances in which human life is potentially at stake. Please contact Renesas Technology Corporation, Renesas Solutions Corporation or an authorized Renesas Technology product distributor when considering the use of a product contained herein for any specific purposes, such as apparatus or systems for transportation, vehicular, medical, aerospace, nuclear, or undersea repeater use.
- The prior written approval of Renesas Technology Corporation and Renesas Solutions Corporation is necessary to reprint or reproduce in whole or in part these materials.
- If these products or technologies are subject to the Japanese export control restrictions, they must be exported under a license from the Japanese government and cannot be imported into a country other than the approved destination. Any diversion or reexport contrary to the export control laws and regulations of Japan and/or the country of destination is prohibited.
- Please contact Renesas Technology Corporation or Renesas Solutions Corporation for further details on these materials or the products contained therein.

### **Precautions to be taken when using this product**

- This product is a development supporting unit for use in your program development and evaluation stages. In mass-producing your program you have finished developing, be sure to make a judgment on your own risk that it can be put to practical use by performing integration test, evaluation, or some experiment else.
- In no event shall Renesas Solutions Corporation be liable for any consequence arising from the use of this product.
- Renesas Solutions Corporation strives to cope with the issues given below at some charge or without charge.
  - (1) Repairing or replacing a flawed product. There can be instances in which a product cannot be repaired if more than one year have passed since the discontinuance of its marketing.
  - (2) Renovating or providing a workaround for product malfunction. This does not necessarily mean that Renesas Solutions Corporation guarantees the renovation or the provision under any circumstances.
- This product has been developed by assuming its use for program development and evaluation in laboratories. Therefore, it does not fall under the application of Electrical Appliance and Material Safety Law and protection against electromagnetic interference when used in Japan.
- Do not attempt to modify this equipment. If modified, your authority to operate this equipment might be voided by FCC.  
Note: This equipment has been tested and found to comply with the limits for a Class A digital device, pursuant to part 15 of the FCC Rules. These limits are designed to provide reasonable protection against harmful interference when the equipment is operated in a commercial environment. This equipment generates, uses, and can radiate radio frequency energy and, if not installed and used in accordance with the instruction manual, may cause harmful interference to radio communications. Operation of this equipment in a residential area is likely to cause harmful interference in which case the user will be required to correct the interference at his own expense.  
Warning: This is a Class A product. In a domestic environment this product may cause radio interference in which case the user may be required to take adequate measures.

For inquiries about the contents of this document or product, fill in the text file the installer of the emulator debugger generates in the following directory and email to your local distributor.

\\SUPPORT\Product-name\SUPPORT.TXT

Renesas Tools Homepage <http://www.renesas.com/en/tools>

# Preface

The M37760T-RPD-E is an emulation pod for the 7700 Family 7770 Series 7760 Group 7760/7762/776A of Renesas 16-bit MCUs. It is used with a PC4701 emulator.

This user's manual mainly describes specifications of the M37760T-RPD-E emulation pod and how to setup it. For details on the following products, which are used with the M37760T-RPD-E, refer to each product's user's manual.

- Emulator: PC4701 User's Manual
- Emulator debugger: M3T-PD77 User's Manual

All the components of this product are shown in "2.1 Package Components" (page 16) of this user's manual. If there is any question or doubt about this product, contact your local distributor.

## To use the product properly

### Precautions for Safety:



- Both in this User's Manual and on the product itself, several icons are used to insure proper handling of this product and also to prevent injuries to you or other persons, or damage to your properties.
- The icons' graphic images and meanings are given in "Chapter 1. Precautions for Safety". Be sure to read this chapter before using the product.

## When using outside Japan



- When using in Europe, the United States, or Canada, be sure to use both the emulator and the emulation pod which meet overseas standards. EMI standards are not met when the M37760T-RPD-E is used with the PC4700H or PC4700L emulator.

# Terminology

Some specific words used in this user's manual are defined as follows:

## **Emulator system**

This means an emulator system built around the PC4701 emulator. The PC4701 emulator system is configured with an emulator main unit, emulation pod, host machine and emulator debugger.

## **Emulator main unit (Hereafter PC4701)**

This means the emulator main units for 8 and 16-bit MCUs. For details on PC4701, visit Renesas Tool Homepage at <http://www.renesas.com/eng/products/mpumcu/toolhp/>

## **Emulation pod main unit**

This means the M37760T-RPD-E (this product). This emulation pod is for the 7770 Series 7760 Group 7760/7762/776A of the 7700 Family MCUs.

## **Host machine**

This means a personal computer used to control the emulator and emulation pod.

## **Emulator debugger**

This means a software tool M3T-PD77 V. 4.00 Release 1 or later to control the emulator from the host machine through an interface.

## **Firmware**

Program that analyzes contents of communication with the emulator debugger and controls the emulator hardware. This program is installed in the EEPROM. This program is downloadable from the emulator debugger to upgrade the firmware or to support other MCUs.

## **Evaluation MCU**

This means the microcomputer mounted on the emulation pod which is operated in the specific mode for tools.

## **Target MCU**

This means the microcomputer you are going to debug.

## **Target system**

This means a user's application system using the MCU to be debugged.

\*

In this user's manual, this symbol is used to show active LOW. (e.g. RESET\*: Reset signal)

# Contents

Chapter 1. Precautions for Safety .....	7
1.1 Safety Symbols and Meanings .....	8
Chapter 2. Preparation .....	15
2.1 Package Components .....	16
2.2 Other Tool Products Required for Development .....	16
2.3 Name of Each Part .....	17
(1) System Configuration .....	17
(2) Inside of the Emulation Pod .....	18
2.4 When Using the Emulator for the First Time .....	19
Chapter 3. Setting Up .....	21
3.1 Removing the Upper Cover .....	22
3.2 Switch Settings .....	23
3.3 Selecting Clock Supply .....	25
(1) Using the Oscillator Circuit on the Target System .....	26
(2) Changing the Internal Oscillator Circuit of the Emulation Pod .....	27
(3) Replacing the Oscillator Circuit Boards .....	28
3.4 Connecting the PC4701 .....	29
(1) Connecting the Cable to the PC4701 .....	29
(2) Connecting the Cable to the Emulation Pod .....	30
3.5 Connecting the Target System .....	31
Chapter 4. Usage .....	33
4.1 Turning On the Power Supply .....	34
(1) Checking the Connection of the System .....	34
(2) Turning On the Power Supply .....	34
(3) LED Display When the PC4701 Starts Up Normally .....	34
4.2 Downloading Firmware .....	35
(1) When It is Necessary to Download Firmware .....	35
(2) Downloading Firmware in Maintenance Mode .....	35
4.3 Starting Up Emulator Debugger - Part 1 (Setting INIT Dialog) .....	36
(1) Setting MCU Tab .....	36
(2) Setting CLOCK Tab .....	37
4.4 Starting Up Emulator Debugger - Part 2 (Setting EMEM Dialog) .....	38
(1) Setting Processor Mode Tab .....	38
(2) Setting MAP Tab .....	38
(3) Setting Debug Monitor Tab .....	39

4.5 Self-check .....	40
(1) Self-check Procedure .....	40
(2) If an Error is Detected in the Self-check .....	40
Chapter 5. Specifications .....	43
5.1 Specifications .....	44
5.2 Memory Mapping .....	45
5.3 Connection Diagram .....	46
5.4 External Dimensions .....	50
(1) External Dimensions of the Emulation Pod .....	50
(2) External Dimensions of the Converter Board .....	51
Chapter 6. Troubleshooting .....	53
6.1 Troubleshooting up to Emulator Debugger Startup .....	54
(1) Errors Displayed over the Emem Dialog Box and Remedial Action .....	55
6.2 When the M37760T-RPD-E Does Not Work Properly .....	56
6.3 How to Request for Support .....	57
Chapter 7. Maintenance and Guarantee .....	59
7.1 Maintenance .....	60
7.2 Guarantee .....	60
7.3 Repair Provisions .....	60
7.4 How to Request for Repair .....	61

# Chapter 1. Precautions for Safety

This chapter describes precautions for using this product safely and properly. For precautions for the emulator main unit, the emulation pod main unit and the emulator debugger, refer to each user's manual included with your product.



1.1 Safety Symbols and Meanings .....	8
<b>WARNING</b> Warning for Installation .....	9
Warnings for Use Environment .....	9
<b>CAUTION</b> Caution to Be Taken for Modifying This Product .....	9
Cautions to Be Taken for Handling This Product .....	9
<b>IMPORTANT</b> Note on Malfunctions in the PC4701 System .....	11
Note on PC4700 System .....	11
Notes on Downloading Firmware .....	11
Note on Processor Mode Register (address D8 <sub>16</sub> ) .....	12
Notes on Target System .....	12
Note on Differences between Actual MCU and Emulator .....	13
Note on ROM Correction Function .....	13
Note on Watchdog Function .....	13
Note on Monitor Work Area of the Emulator .....	14
Note on Software Breaks .....	14
Note on Reading Out the MCU Internal Resources .....	14
Note on Watch Point .....	14
Note on Event Breaks .....	14

# Chapter 1. Precautions for Safety

In both the user's manual and on the product itself, several icons are used to insure proper handling of this product and also to prevent injuries to you or other persons, or damage to your properties.

This chapter describes the precautions which should be taken in order to use this product safely and properly. Be sure to read this chapter before using this product.

## 1.1 Safety Symbols and Meanings

	<b>WARNING</b>	If the requirements shown in the "WARNING" sentences are ignored, the equipment may cause serious personal injury or death.
	<b>CAUTION</b>	If the requirements shown in the "CAUTION" sentences are ignored, the equipment may malfunction.
	<b>IMPORTANT</b>	It means important information on using this product.

In addition to the three above, the following are also used as appropriate.

△ means WARNING or CAUTION.  
Example:  **CAUTION AGAINST AN ELECTRIC SHOCK**

⊘ means PROHIBITION.  
Example:  **DISASSEMBLY PROHIBITED**

● means A FORCIBLE ACTION.  
Example:  **UNPLUG THE POWER CABLE FROM THE RECEPTACLE.**

The following pages describe the symbols "WARNING", "CAUTION", and "IMPORTANT".



## WARNING

### Warning for Installation:



- Do not set this product in water or areas of high humidity. Spilling water or some other liquid into the main unit can cause an unreparable damage.

### Warnings for Use Environment:



- The emulation pod is air-cooled with the ventilation slot. Therefore, do not block the ventilation slot. When heated to high temperatures, the emulation pod may not work properly.
- This equipment is to be used in an environment with a maximum ambient temperature of 35°C. Care should be taken that this temperature is not exceeded.

## CAUTION

### Caution to Be Taken for Modifying This Product:



- Do not disassemble or modify this product. Disassembling or modifying this product can cause damage. Disassembling and modifying the product will void your warranty.

### Cautions to Be Taken for Handling This Product:



- Use caution when handling the main unit. Be careful not to apply a mechanical shock.
- Do not touch the connector pins of the emulator main unit and the target MCU connector pins. Static electricity may damage the internal circuits.
- Do not pull the emulation pod by the flexible cable (FLX120-RPD) for connecting to the emulator main unit or the flexible cable (FLX100) for connecting the target system. The cable may cause a break.
- The flexible cable (FLX120-RPD) for connecting to the emulator main unit and the flexible cable (FLX100) for connecting the target system are different from earlier models. The slits make them more flexible. However, excessive flexing or force may break conductors. "Figure 1.1 Note on handling the flexible cable (FLX100)" (next page) shows the examples of excessively flexed cables and how to handle them.
- Do not use inch-size screws for this equipment. The screws used in this equipment are all ISO (meter-size) type screws. When replacing screws, use same type screws as equipped before.

### Example 1

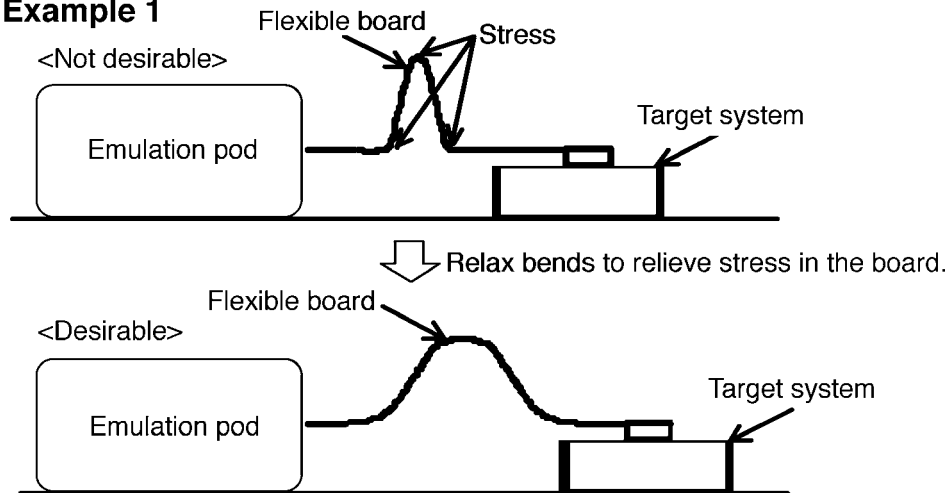

### Example 2

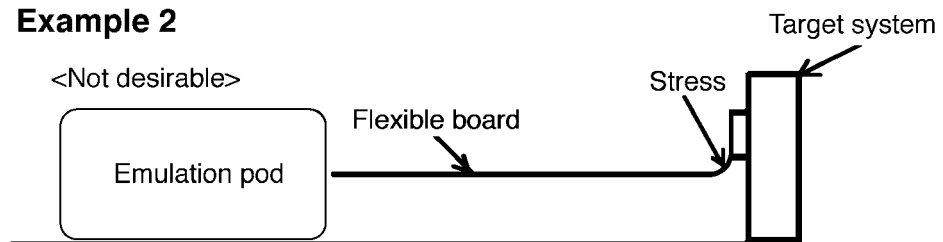

- (1) Set the target system on a platform to relax bends and relieve stress in the board.
- (2) The boundary between the firm and flexible parts of the flexible board does not readily bend. Do not bend it excessively.

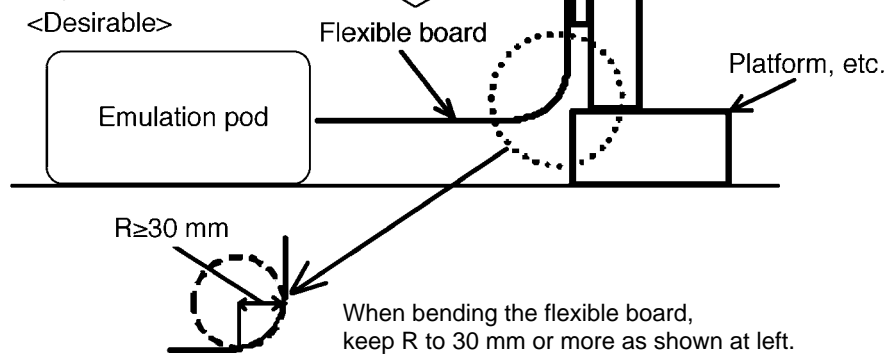

Figure 1.1 Note on handling the flexible cable (FLX100)

# IMPORTANT

## Note on Malfunctions in the PC4701 System:

- If the emulator malfunctions because of interference such as external noise, do the following to remedy the trouble.
  - (1) Press the RESET button on the emulator front panel.
  - (2) If normal operation is not restored after step (1), shut OFF power to the emulator once and then reactivate it.

## Note for PC4700 System:

- PC4700H products whose serial number ends with a number or D, DE, G cannot be used with the M37760T-RPD-E.  
Example: 5KE100, 5KE100D, 5KE11DE, 5KE100G  
Cannot be used with the M37760T-RPD-E. Upgrade your PC4700.
- Example: 5LE123B  
Can be used with the M37760T-RPD-E.

## Notes on Downloading Firmware:

- Before using this product for the first time, it is necessary to download the dedicated firmware (control software for the emulation pod built into the PC4701). Please note that, to do this, it is necessary to start up the PC4701 in maintenance mode. For firmware download procedures, see "4.2 Downloading Firmware" (page 35). Once the firmware has been downloaded, the product can be used by simply turning on the power.
- Do not shut off the power while downloading the firmware. If this happens, the product will not start up properly. If power is shut off unexpectedly, redownload the firmware.
- Except when a target status error occurs, if self-checks are not completed successfully, there may be trouble with the product. In such case, contact your sales representative. However, perform self-checks in the below setup.
  - (1) Target system: Not connected
  - (2) Emulation pod internal switches: At their factory settings

# IMPORTANT

## Note on Processor Mode Register (address D8<sub>16</sub>):

- When using this product, the following precautions must be observed with the processor mode register 0 in addition to those for the actual MCU.

(1) Software reset bit (bit 3)

If "1" is set for the software reset bit when the user program is not running, the MCU will be reset while debug commands are being executed, thus commands will not end as they normally do.

(2) Wait bit (bit 2)

With the emulator the areas affected by the wait bit differ from those of the actual MCU such as mask ROM version or EPROM version MCUs.

(3) Processor mode bits (bit 1 and bit 0)

"00" is always read for the processor mode bits. To set the processor mode bits, be sure to set "00". Setting other values can cause a malfunction.

## Notes on Target System:

- The Vcc pin is connected to the target system to observe the voltage of the target system. Therefore the emulator cannot supply the power to the target system. Design your system so that the target system is powered separately.
- The voltage of the target system should be within the MCU's specified range and between +2.6 and 5.5 V.
- Do not change the voltage of the target system after turning on the power.
- Before powering on your emulator system, check that the host machine, the PC4701, converter board and target system are all connected correctly. Next, turn on the power to each equipment following the procedure below.

(1) Turn ON/OFF the target system and the PC4701 as simultaneously as possible.

(2) When the PC4701 and emulator debugger M3T-PD77 start up, check the target status LEDs on the emulator main unit's front panel to see if this product is ready to operate.

(For the target status LEDs on the emulator main unit's front panel when starting up the PC4701, refer to "4.1 (3) LED Display When the PC4701 Starts Up Normally" on page 34.)

# IMPORTANT

## Note on Differences between Actual MCU and Emulator:

- Operations of the emulator differ from those of mask MCUs as listed below.

- (1) Reset condition
- (2) Power voltage
- (3) Initial values of internal resource data at power-on
- (4) Internal memory (ROM and RAM) capacities, etc.
- (5) XIN and XOUT pins

Make note of the fact that in the oscillator circuit where a resonator is connected between the XIN and XOUT pins, oscillation does not occur because a flexible cable, buffer IC and other devices are used between the evaluation MCU and the target system. See "Figure 3.4 Circuit in which oscillation does not occur (same for XCIN -XCOUT)" (page 26).

- (6) XCIN and XCOUT pins

Make note of the fact that in the oscillator circuit where a resonator is connected between the XCIN and XCOUT pins, oscillation does not occur because a flexible cable, buffer IC and other devices are used between the evaluation MCU and the target system. See "Figure 3.4 Circuit in which oscillation does not occur (same for XCIN -XCOUT)" (page 26).

- (7) NUA and NUB pins

The NUA and NUB pins are not connected to the evaluation MCU.

- (8) Other pins

As a flexible cable is used between the evaluation MCU and the target system, electrical characteristics are different from those of the actual MCU.

**Therefore, be sure to evaluate your system with an evaluation MCU. Before starting mask production, evaluate your system and make final confirmation with an ES (Engineering Sample) version MCU.**

## Note on ROM Correction Function:

- When evaluating the ROM correction function, use an actual MCU.

## Note on Watchdog Function:

- The MCU's watchdog timer can be used only while programs are being executed. To use it otherwise, disable the watchdog timer.

# IMPORTANT

## Note on Monitor Work Area of the Emulator:

- Please note that this emulator uses the following areas of the MCU access space as monitor work areas. For details, refer to "5.2 Memory Mapping" (page 45).

- (1) User stack: Part of the user stack area from the address indicated by the stack pointer toward the lower address direction. (Normally 9 bytes, Max. 14 bytes)
- (2) Monitor work area: Part of an area in bank 00 (any 6 bytes)  
Part of the vector area in bank 00 (Min. 2 bytes, Max. 4 bytes)
- (3) Debug bank: Bank FF

## Note on Software Breaks:

- Software breaks generate break interruptions by forcibly inserting a BRK instruction "00h" instead of an instruction code. Therefore, when referencing the result of a trace in bus mode, "00h" is displayed for the instruction fetch address where a software break is set.

## Note on Reading Out the MCU Internal Resources:

- Reading out the SFR area with this product and the emulator debugger will be resulted in the following. (The content of this area is not displayed correctly while data in the MCU is not affected.)

- (1) Result of real-time trace  
Data of the cycle when the SFR area is readout is not displayed properly.
- (2) Real-time RAM monitor  
Data of the cycle when the SFR area is readout is not displayed properly.

## Note on Watch Point:

- When you set a watch point over the SFR area with this product and the emulator debugger, the following should be noted.

- (1) Make sure the address specified for a watch point and the addresses set for the real-time RAM monitor (you can check by the RRAM command of the M3T-PD77) do not overlap one another.  
When the address specified for a watch point and the addresses set for the real-time RAM monitor overlap one another and the SFR area is readout, data is not displayed properly.  
The initial setting of the real-time RAM monitor is 0000H to 03FFH.

Example: When you want to set a watch point at 0000H, change the addresses for the real-time RAM monitor to 0010H to 040FH.

## Note on Event Breaks:

- With this product and the emulator debugger, you can not use data readout from the SFR area as a condition for event breaks.

# Chapter 2. Preparation

This chapter describes the package components, the system configuration and the preparation for using this product for the first time.

2.1 Package Components .....	16
2.2 Other Tool Products Required for Development .....	16
2.3 Name of Each Part .....	17
(1) System Configuration .....	17
(2) Inside of the Emulation Pod .....	18
2.4 When Using the Emulator for the First Time .....	19

# Chapter 2. Preparation

## 2.1 Package Components

This product consists of the following items. When unpacking, check to see if your product package contains all of these items.

### *Package components*

Item	Quantity
M37760T-RPD-E emulation pod main unit	1
FLX120-RPD flexible cable for connecting PC4701	1
M3T-FLX-100LCC pitch converter board for 100-pin LCC	1
OSC-2 oscillation circuit board (bare)	1
Hardware tool user registration FAX sheet (English)	1
Hardware tool user registration FAX sheet (Japanese)	1
M37760T-RPD-E User's Manual (this manual)	1
M37760T-RPD-E User's Manual (Japanese)	1

Please keep the M37760T-RPD-E's packing box and cushion material in your place for reuse at a later time when sending your product for repair or other purposes. Always use these packing box and cushion material when transporting the M37760T-RPD-E.

If any of these items are missing or found faulty, please contact your local distributor. Also, if there is any question or doubt about the packaged product, contact your local distributor.

## 2.2 Other Tool Products Required for Development

To bring forward programs development on the 7760 Group 7760/7762/776A MCUs, the products listed below are necessary in addition to the package components listed above. Get them separately.

### *Other tool products*

Emulator main unit	PC4701
Emulator debugger	M3T-PD77 (V.4.00 Release 1 or later)
Converter board	For 100-pin 0.65-mm-pitch QFP (100P6P-E): M3T-FLX-100LCC (Please prepare separately the LCC socket IC61-1004-051 for connecting to the target system.) M3T-FLX-100NRB M3T-DUMMY100S M3T-DIRECT100S  The converter board which matches to the foot pattern of the target system is required. (For connecting to the target system, see "3.5 Connecting the Target System" on page 31.)

\* To purchase these products, contact your local distributor.

\* To purchase the LCC socket IC61-1004-051, contact your local distributor or Yamaichi Electronics Co., Ltd.



## 2.3 Name of Each Part

### (1) System Configuration

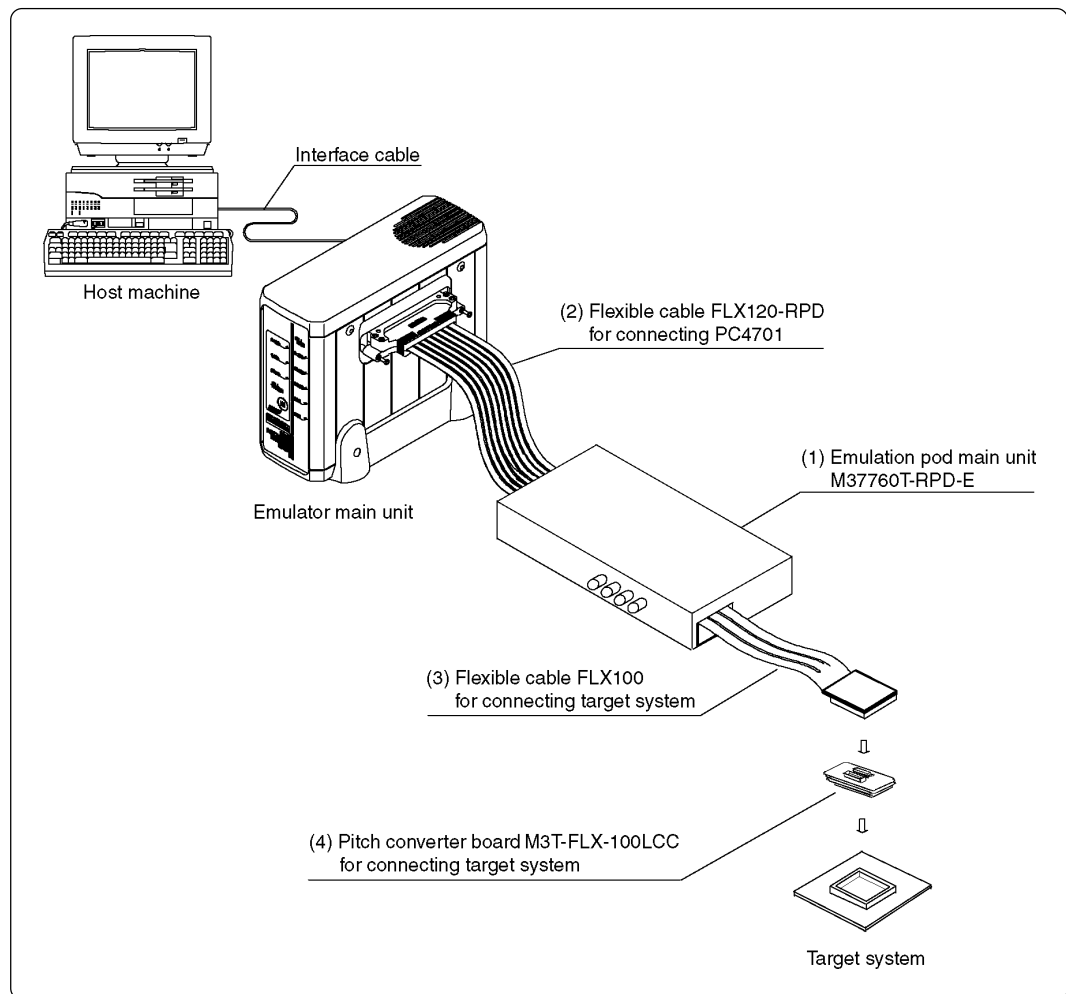

Figure 2.1 System configuration

(1) to (4) in Figure 2.1 are included in this product package.

(1) Emulation pod (M37760T-RPD-E)

This emulation pod contains an evaluation MCU, emulation memory and circuit to feature the debugging functions.

(2) Flexible cable (FLX120-RPD)

This 120-pin flexible cable connects the PC4701 emulator and the emulation pod.

(3) Flexible cable (FLX100)

This 100-pin flexible cable connects the emulation pod and the target system.

(4) Pitch converter board (M3T-FLX-100LCC)

This is a pitch converter board for connecting to the 100-pin LCC socket on the target system. For details, refer to "3.5 Connecting the Target System" (page 31).

## (2) Inside of the Emulation Pod

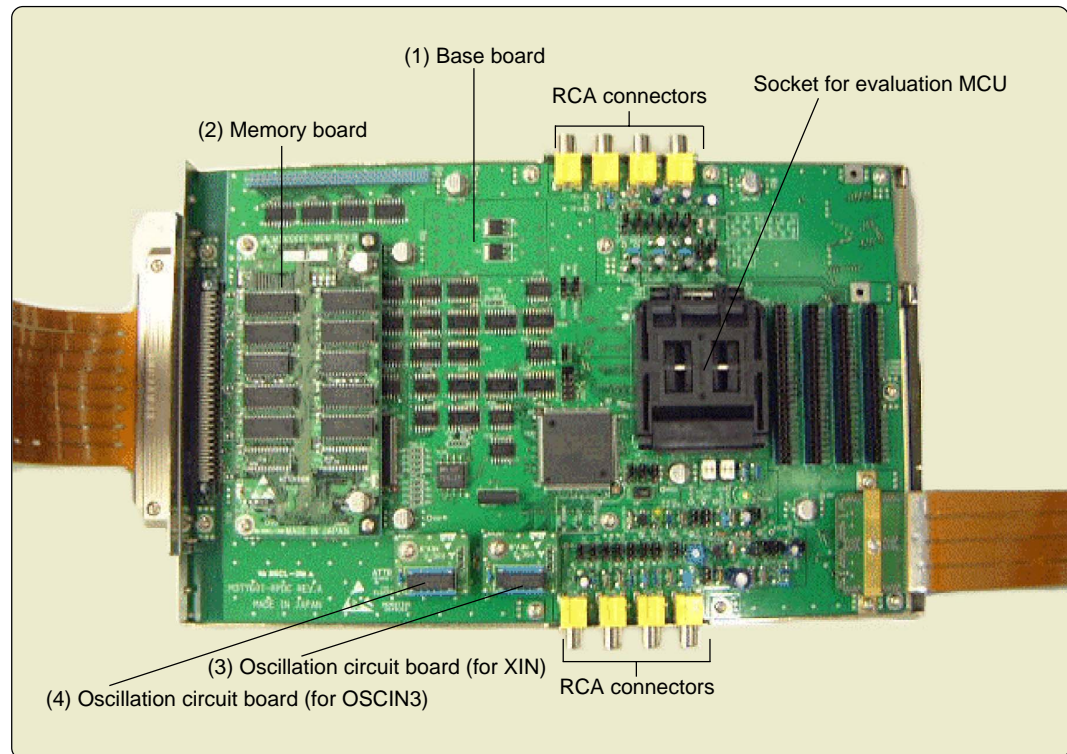

Figure 2.2 Internal view of the emulation pod

### (1) Base board

Base board for the 7760 Group 7760/7762/776A MCUs which controls the interface of the PC4701 and evaluation MCU.

### (2) Memory board

Board on which the 1MB emulation memory is mounted.

### (3) Oscillation circuit board (for XIN)

Oscillation circuit board for XIN. Operating frequency can be changed by replacing this board with other available oscillation circuit boards.

### (4) Oscillation circuit board (for OSCIN3)

Oscillation circuit board for OSCIN3. Operating frequency can be changed by replacing this board with other available oscillation circuit boards.

## 2.4 When Using the Emulator for the First Time

If you have purchased this emulation pod newly, it is necessary to download the firmware. The download procedure is given in Figure 2.3.

Before attempting to download the firmware, check the emulator debugger is installed and the emulator is connected to the host machine. For more information, see each user's manual of the emulator debugger and the PC4701.

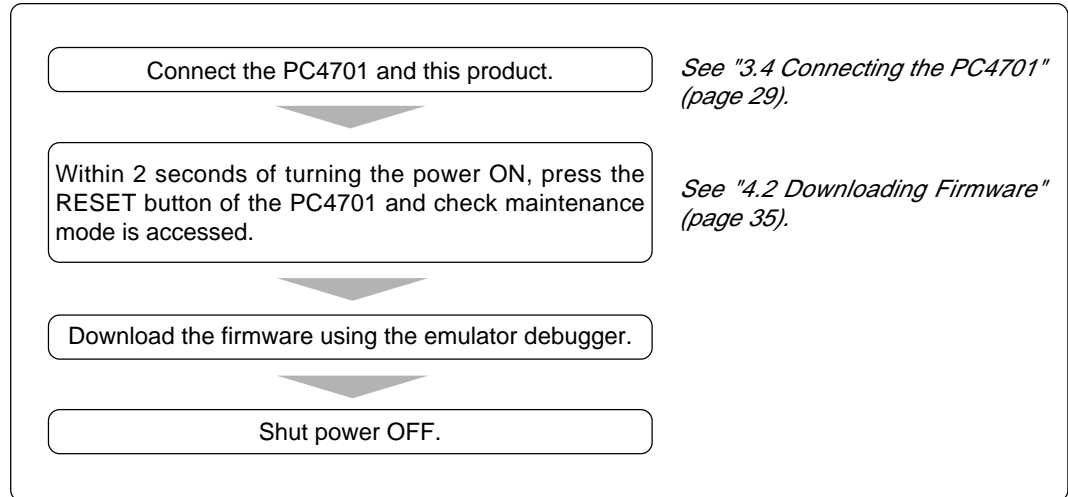

Figure 2.3 Firmware download procedure when emulator is used for the first time

To make sure the emulation pod works properly, run the self-checks. For self-check procedures, see "4.5 Self-check" (page 40).

# MEMO

# Chapter 3. Setting Up

This chapter describes switch settings required for using this product and how to connect this product to the PC4701 and the target system.

3.1 Removing the Upper Cover .....	22
3.2 Switch Settings .....	23
3.3 Selecting Clock Supply .....	25
(1) Using the Oscillator Circuit on the Target System .....	26
(2) Changing the Internal Oscillator Circuit of the Emulation Pod .....	27
(3) Replacing the Oscillator Circuit Boards .....	28
3.4 Connecting the PC4701 .....	29
(1) Connecting the Cable to the PC4701 .....	29
(2) Connecting the Cable to the Emulation Pod .....	30
3.5 Connecting the Target System.....	31

# Chapter 3. Setting Up

With this product, it is necessary to set the following according to your target system. Set the following after removing the upper cover.

- Setting XIN/XOUT pins
- Setting XCIN/XCOUT pins
- Changing the input frequency
- Setting the MCU peripheral functions

## 3.1 Removing the Upper Cover

The procedure of removing the upper cover is shown below.

- (1) Remove the eight screws of this product and lift off the upper cover (see Figure 3.1).
- (2) Set the jumper switches.
- (3) Replace the upper cover and secure it with the eight screws.

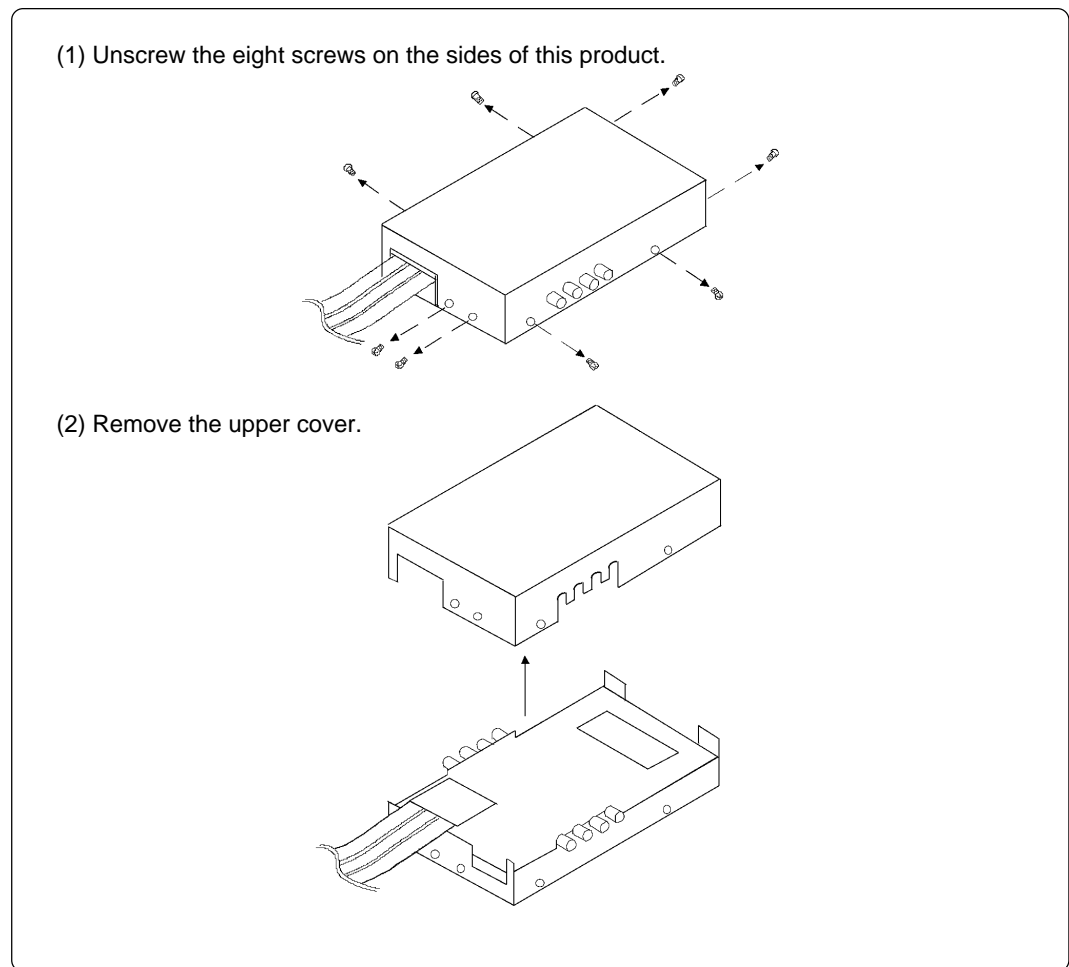

Figure 3.1 Removing the upper cover

### CAUTION

#### When Removing the Upper Cover:

- Always shut OFF power when removing the upper cover or setting the switches.

### 3.2 Switch Settings

Figure 3.2 shows the positions of the switches and Table 3.1 shows each switch setting.

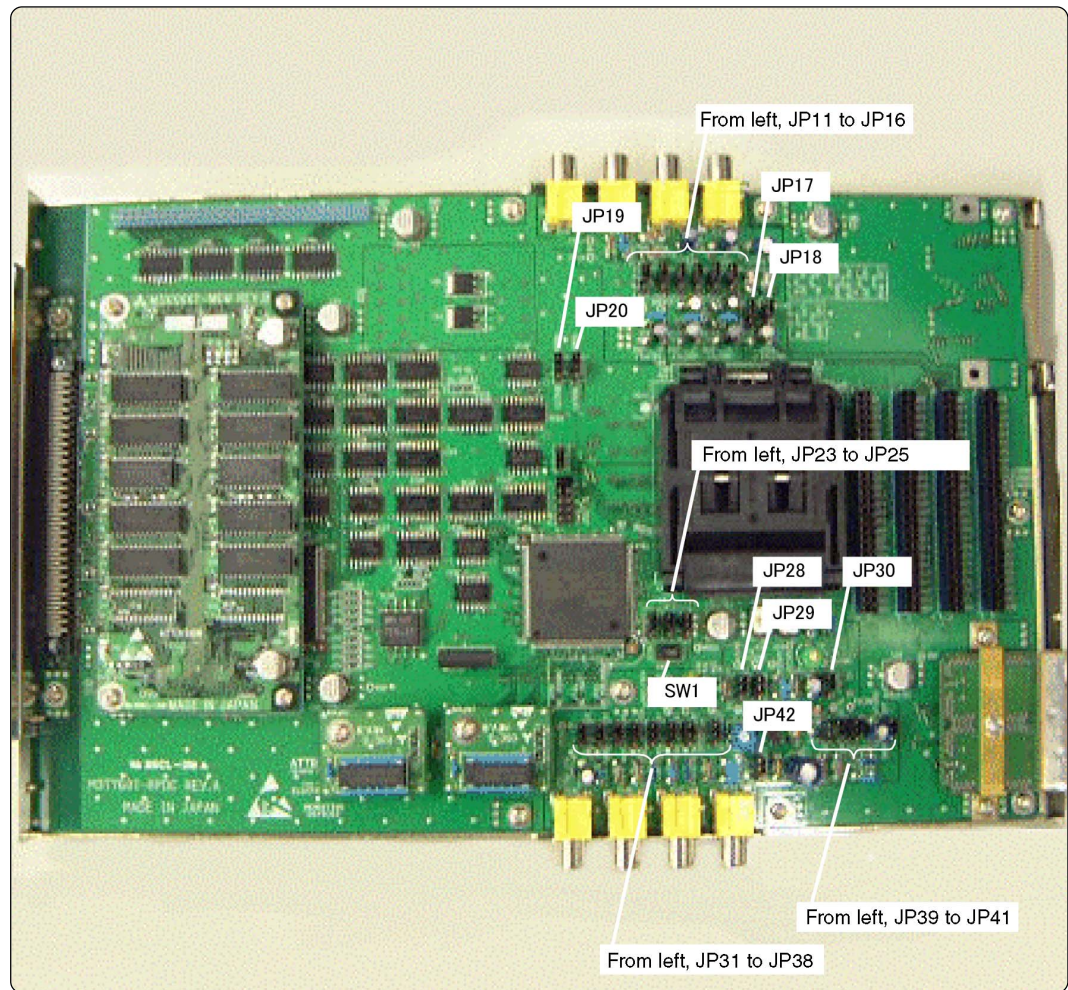
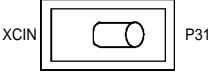





Figure 3.2 Positions of the switches and their factory-settings

\* For the circuit configuration of these switches, refer to "5.3 Connection Diagram" (page 46).

Table 3.1 Switch settings of the M37760T-RPD-E

Switch setting		Description	
SW1	 <p>(Factory-setting)</p>	<b>P31 side</b> When using P31/XCIN pin as a port, set to P31 side.	<b>XCIN side</b> When using P31/XCIN pin as a sub-clock, set to XCIN side.
JP23	 <p>(Factory-setting)</p>	<b>USENSE side</b> <u>Be sure to fix to this side.</u>	<b>NC side</b> Do not use this side.
JP24	 <p>(Factory-setting)</p>	<b>XOUT side</b> Connects the XOUT pin to the target system.	<b>NC side</b> Does not connect the XOUT pin to the target system. XOUT pin is open.
JP25	 <p>(Factory-setting)</p>	<b>P30/XCOUT side</b> Connects the XCOUT/P30 pin to the target system.	<b>NC side</b> Does not connect the XCOUT/P30 pin to the target system. XCOUT/P30 pin is open.
JP11-JP18 JP26-JP41	These switches are related to the peripheral circuit of the MCU such as OSD. For the specifications of these switches, see "5.3 Connection Diagram" (page 46).		



### 3.3 Selecting Clock Supply

There are two ways to supply a clock to the MCU, using the oscillator circuit of the emulation pod or using the oscillator circuit on the target system. Table 3.2 shows the factory-settings of each clock supply.

Table 3.2 Clock supply to the MCU

Clock	Description	Display of emulator debugger	Factory-setting
XIN-XOUT	Internal oscillator circuit of emulation pod (OSC-3: 16 MHz)	Internal	Yes
	Target system	External	-
XCIN-XCOUT	Internal oscillator circuit of emulation pod (32.768 kHz)	Internal	-
	Target system	External	Yes

## IMPORTANT

### Note on Changing the Clock Supply:

- For using P31/XCIN pin as a sub-clock, it is necessary to set the SW1 in the emulation pod to XCIN side. For how to set the switches, refer to "3.2 Switch Settings" (page 23).
- The clock supply of XIN-XOUT and XCIN-XCOUT pins can be set by the Init dialog when starting up the emulator debugger or inputting CLK command on the script window. The examples of CLK command are below.

Example 1. When selecting the internal oscillator circuit of the emulation pod  
CLK INT,INT

Example 2. When selecting the oscillator circuit on the target system  
CLK EXT,EXT

## (1) Using the Oscillator Circuit on the Target System

When turning on the power supply, the internal clock of the emulation pod is selected to supply the clock to the MCU. To use the external clock on the target system, change the clock by the CLK command of the emulator debugger. (For details, refer to the user's manual of the emulator debugger.)

# IMPORTANT

## Notes on Operating with the External Clock:

- To operate the emulation pod with an oscillator on the target system, construct the oscillator circuit as shown in Figure 3.3 in the target system and input the oscillator output at 50% duty (within the operating range of the evaluation MCU) into the XIN or XCIN pins. And the XOUT, XCOOUT pins should be open.
- Make note of the fact that in the oscillator circuit shown in Figure 3.4 where a resonator is connected between the XIN and XOUT pins, oscillation does not occur because a connector and other devices are used between the evaluation MCU and the target system. It is same for sub-clock oscillator circuits (XCIN and XCOOUT).

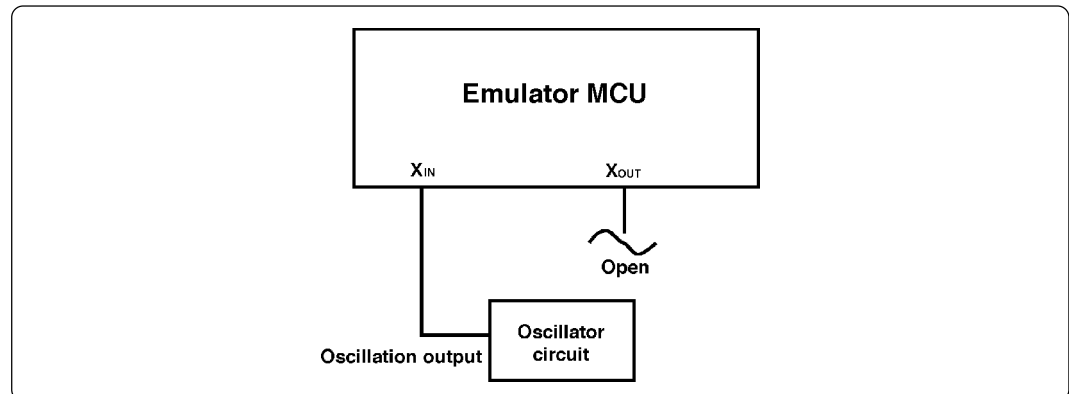

Figure 3.3 External oscillator circuit

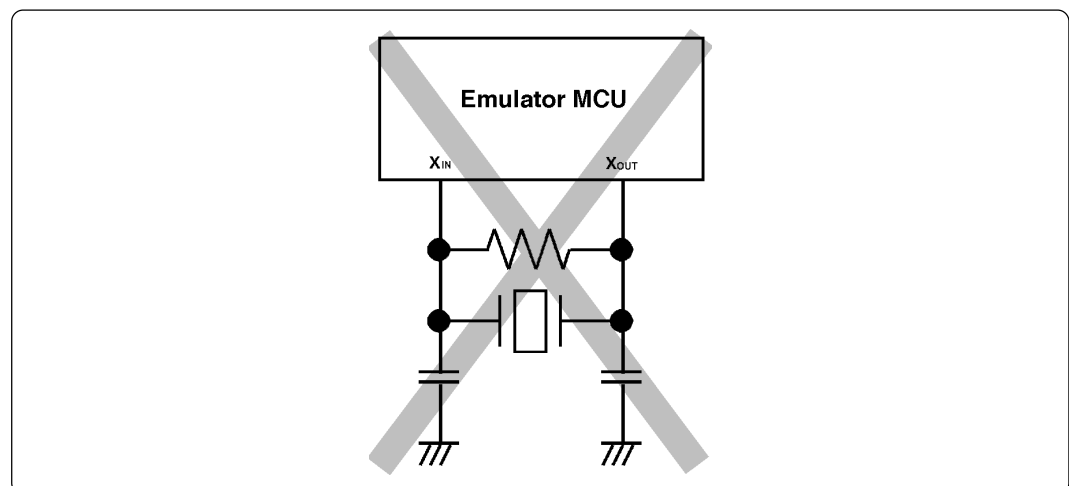

Figure 3.4 Circuit in which oscillation does not occur (same for XCIN -XCOOUT)

## (2) Changing the Internal Oscillator Circuit of the Emulation Pod

An oscillator circuit board for 16 MHz (for XIN) and 14.318 MHz (for OSCIN3) are mounted on the emulation pod. To use the emulation pod at a frequency other than 16 MHz or 14.318 MHz, build the desired oscillator circuit on the included OSC-2 oscillator circuit board (bare board) and replace the board installed in the emulation pod when shipped from the factory.

Figure 3.5 shows an external view of the OSC-2 oscillator circuit board (bare board) and where connector pins are located. Figure 3.6 shows the circuitry of the OSC-2 oscillator circuit board (bare board). Use the number of oscillator circuits recommended by the oscillator manufacturer.

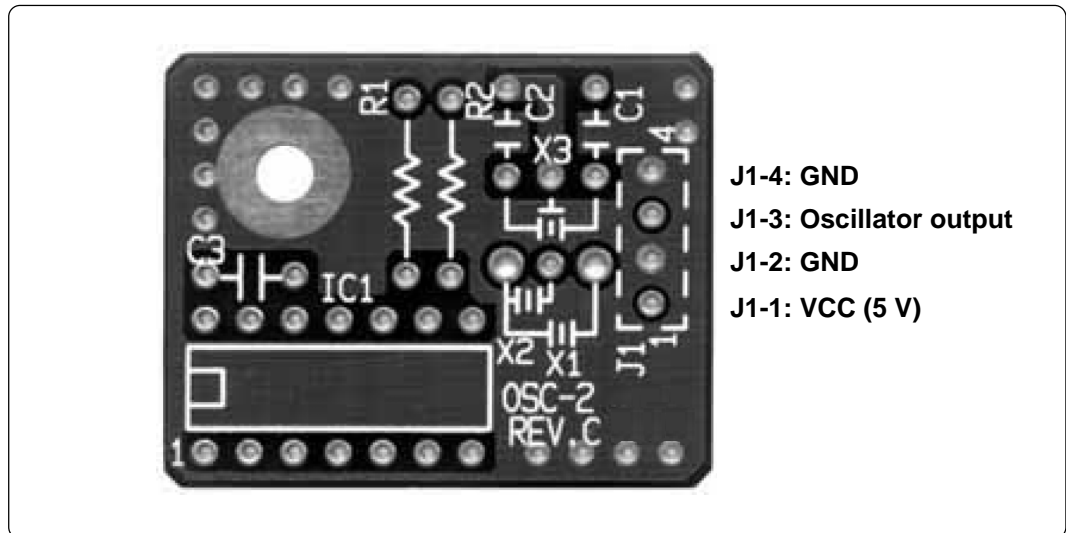

Figure 3.5 External view of the oscillator board (OSC-2) and connector pin assignment

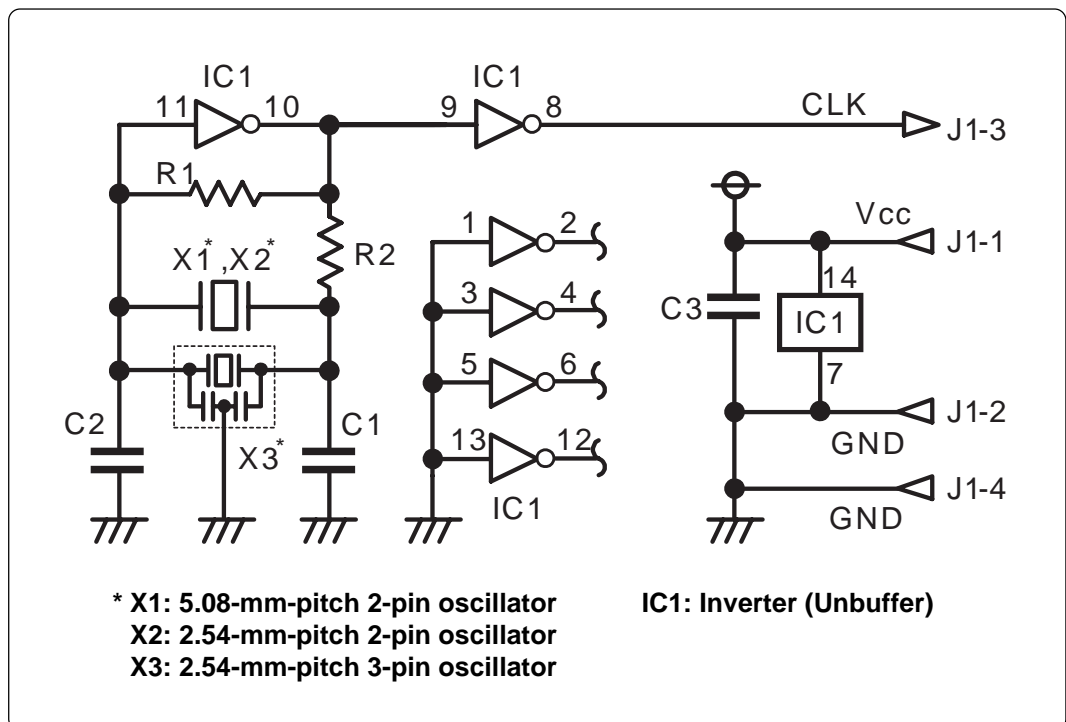

Figure 3.6 Circuit of the oscillator board (OSC-2)

### (3) Replacing the Oscillator Circuit Boards

Figure 3.7 shows how to replace the oscillator circuit boards. For the position of the oscillator circuit board, see "Figure 2.2 Internal view of the emulation pod" (page 18).

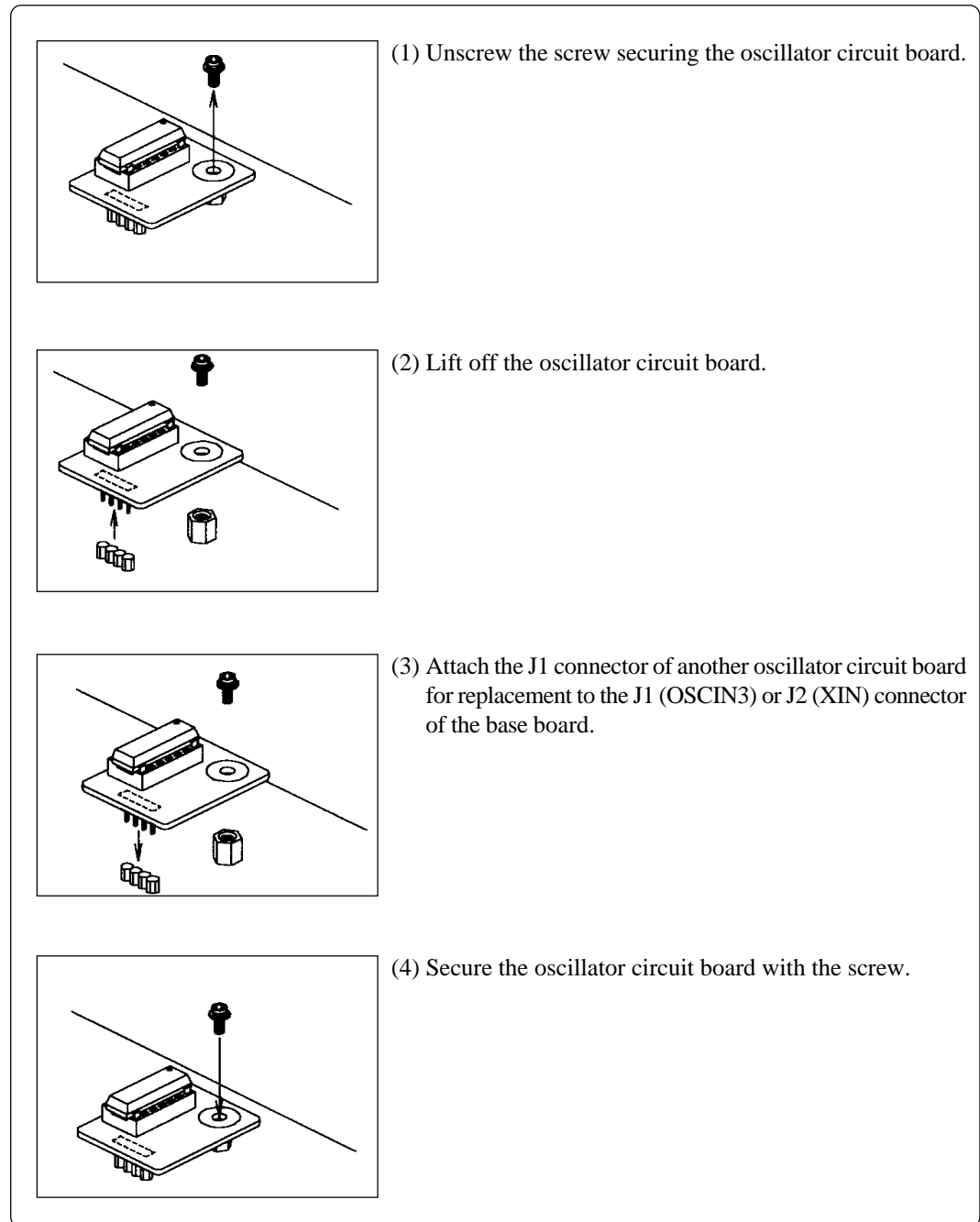

Figure 3.7 Replacing the oscillator circuit boards

### 3.4 Connecting the PC4701

To connect the emulation pod to the PC4701, use the FLX120-RPD 120-pin flexible cable included in this product package. Connect the PC4701 side connector of the FLX120-RPD to the cable connector of the PC4701, then secure with screws.

#### (1) Connecting the Cable to the PC4701

Figure 3.8 shows how to connect the PC4701 and FLX120-RPD.

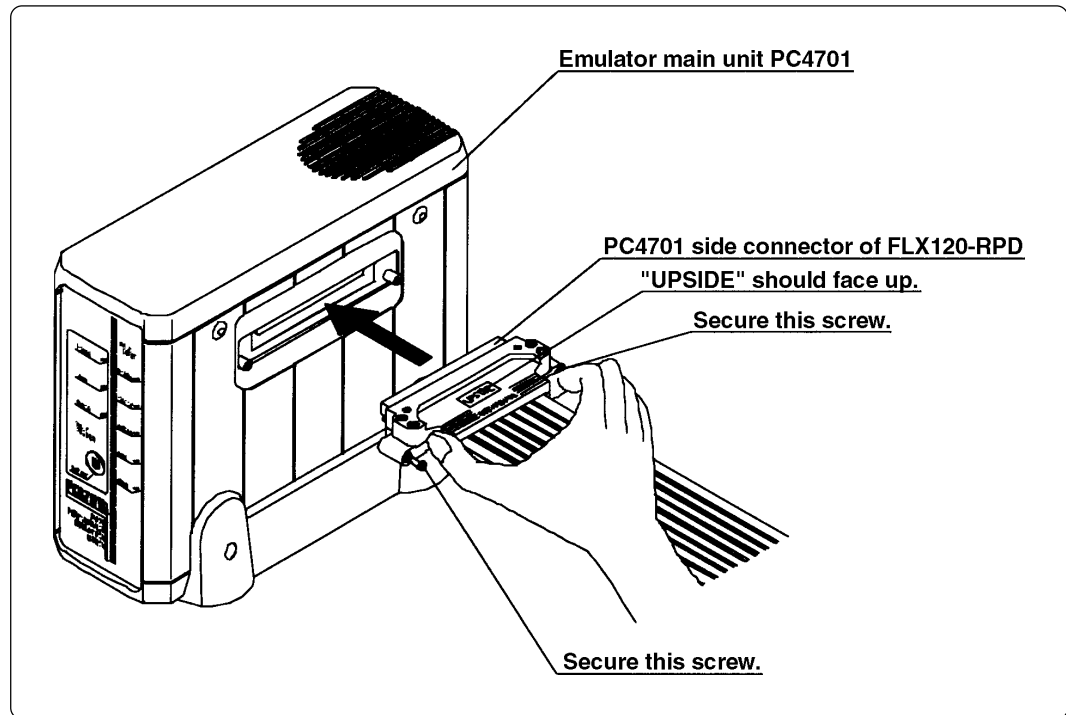

Figure 3.8 Connecting the PC4701 and FLX120-RPD

## CAUTION

### Note on Connecting the Cable:

- To connect the FLX120-RPD, be sure to hold the both sides of the PC4701 side connector horizontally with the "UPSIDE" facing up.
- Always shut OFF power before connecting the cable. The power ON state could destroy internal circuits.

### Note on Securing the Screws:

- After connecting the emulator main unit to the FLX120-RPD, be sure to secure the screws.

## (2) Connecting the Cable to the Emulation Pod

Figure 3.9 shows how to connect the FLX120-RPD and the emulation pod.

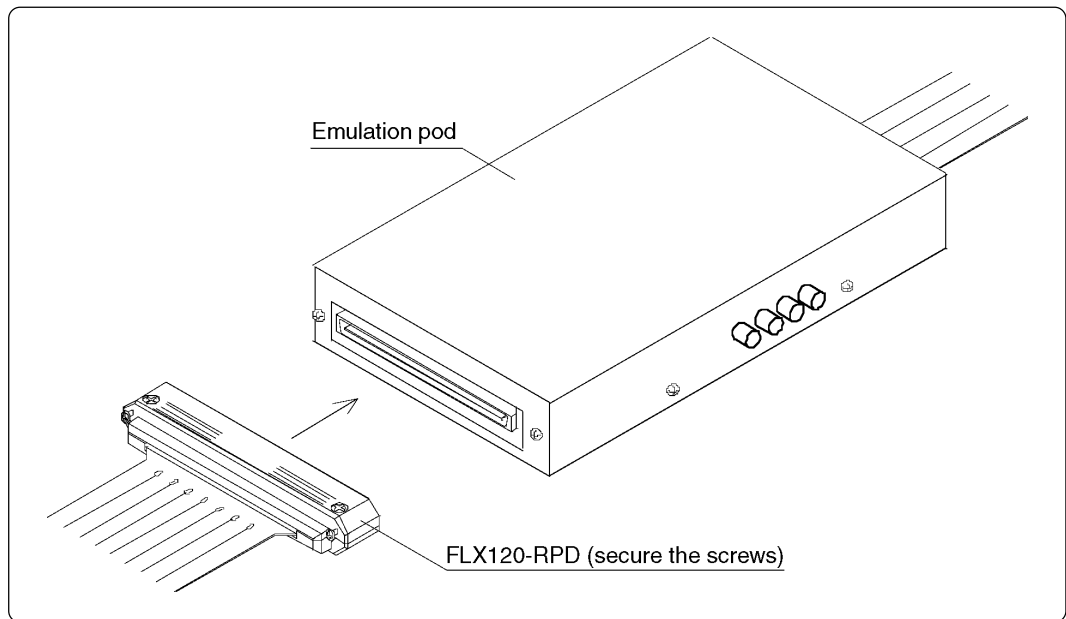

Figure 3.9 Connecting emulation pod and FLX120-RPD

### CAUTION

#### Note on Connecting the Cable:

- Always shut OFF power before connecting the cable. The power ON state could destroy internal circuits.

#### Note on Securing the Screws:

- After connecting the emulator main unit to the cable, be sure to secure the screws.

### 3.5 Connecting the Target System

There are four ways available to connect the emulation pod to target system as shown in Figure 3.10.

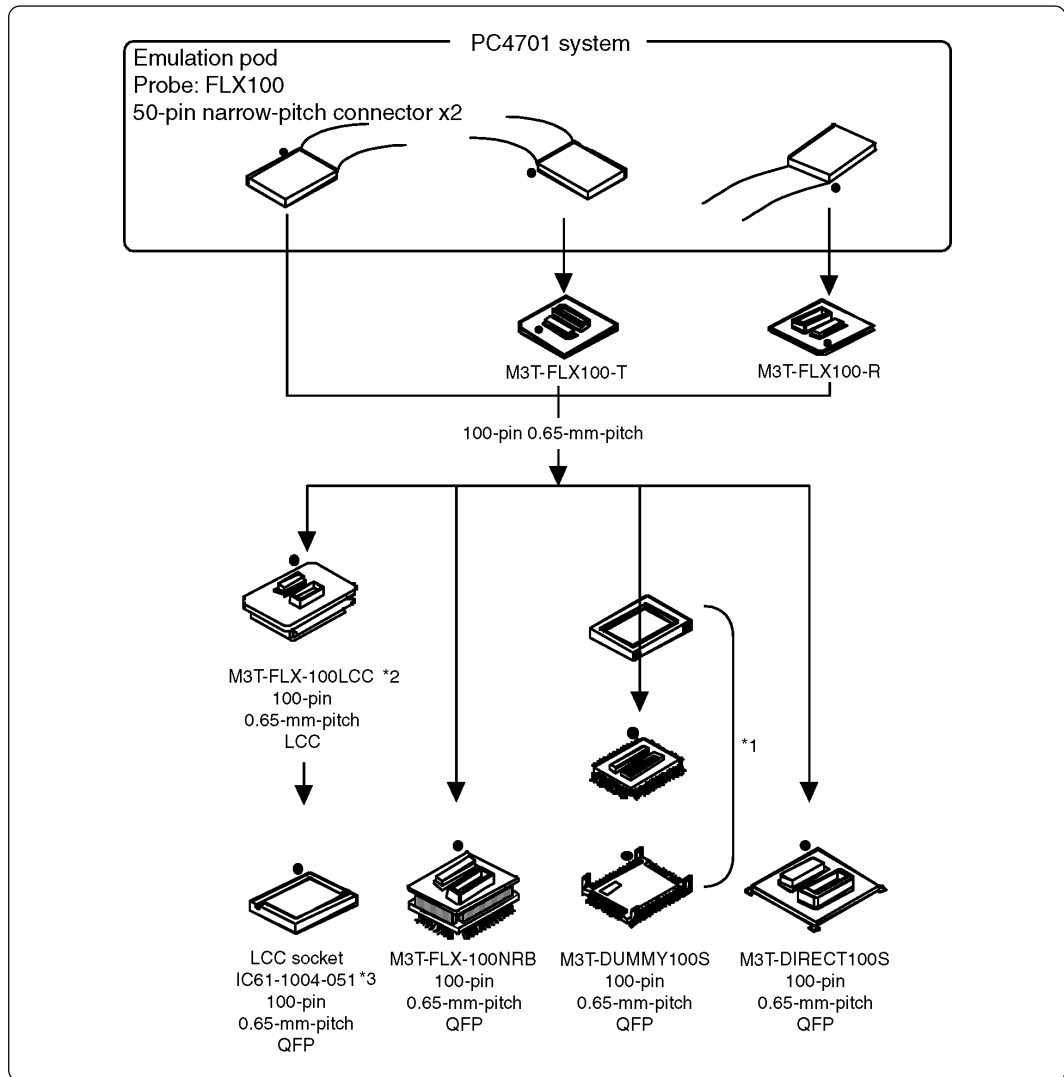

Figure 3.10 Connecting emulation pod and target system

\*1 These three items are available in one package.

\*2 M3T-FLX-100LCC is included in this emulation pod package.

\*3 To purchase IC socket IC61-1004-051 (manual soldering type), contact your local distributor or Yamaichi Electronics Co., Ltd.

\* To purchase M3T-FLX100-T, M3T-FLX100-R, M3T-DUMMY100S and M3T-DIRECT100S, contact your local distributor.

## ! CAUTION

### Notes on Connecting the Target System:

1. Always shut OFF power before connecting the target system. The power ON state could destroy internal circuits.
2. The small connectors of the FLX100 and M3T-FLX-100LCC are guaranteed for only 20 insertion/removal iterations.
3. Take care not to attach the converter board in a wrong direction. It may cause a fatal damage to the emulation pod.

# MEMO



# Chapter 4. Usage

This chapter describes from turning on the power of this product to starting up the emulator debugger.

4.1	Turning On the Power Supply .....	34
	(1) Checking the Connection of the System .....	34
	(2) Turning On the Power Supply .....	34
	(3) LED Display When the PC4701 Starts Up Normally .....	34
4.2	Downloading Firmware .....	35
	(1) When It is Necessary to Download Firmware .....	35
	(2) Downloading Firmware in Maintenance Mode .....	35
4.3	Starting Up Emulator Debugger - Part 1 (Setting INIT Dialog) .....	36
	(1) Setting MCU Tab .....	36
	(2) Setting CLOCK Tab .....	37
4.4	Starting Up Emulator Debugger - Part 2 (Setting EMEM Dialog) .....	38
	(1) Setting Processor Mode Tab .....	38
	(2) Setting MAP Tab .....	38
	(3) Setting Debug Monitor Tab .....	39
4.5	Self-check .....	40
	(1) Self-check Procedure .....	40
	(2) If an Error is Detected in the Self-check .....	40

# Chapter 4. Usage

## 4.1 Turning On the Power Supply

### (1) Checking the Connection of the System

Before turning the power ON, check the connection of the PC4701, emulation pod, converter board and target system.

### (2) Turning On the Power Supply

Power ON/OFF the target system and the PC4701 as simultaneously as possible.

 **CAUTION**

**Notes on Power Supply:**

- The emulator's V<sub>CC</sub> pin is connected to the target system in order to monitor target system voltage. For this reason, the emulator cannot supply power to the target system. Therefore, provide the target system with a separate power supply from that of the emulator.
- Keep target system power supply voltage within the MCU's specified range and between +2.6 and 5.5 V.
- Do not change target system power supply voltage after power has been activated.

### (3) LED Display When the PC4701 Starts Up Normally

After the emulator starts up, check the status of the LEDs on the front panel to see whether emulation pod operation is enabled or not. Figure 4.1 shows front panel LED lighting status when the emulator is turned ON.

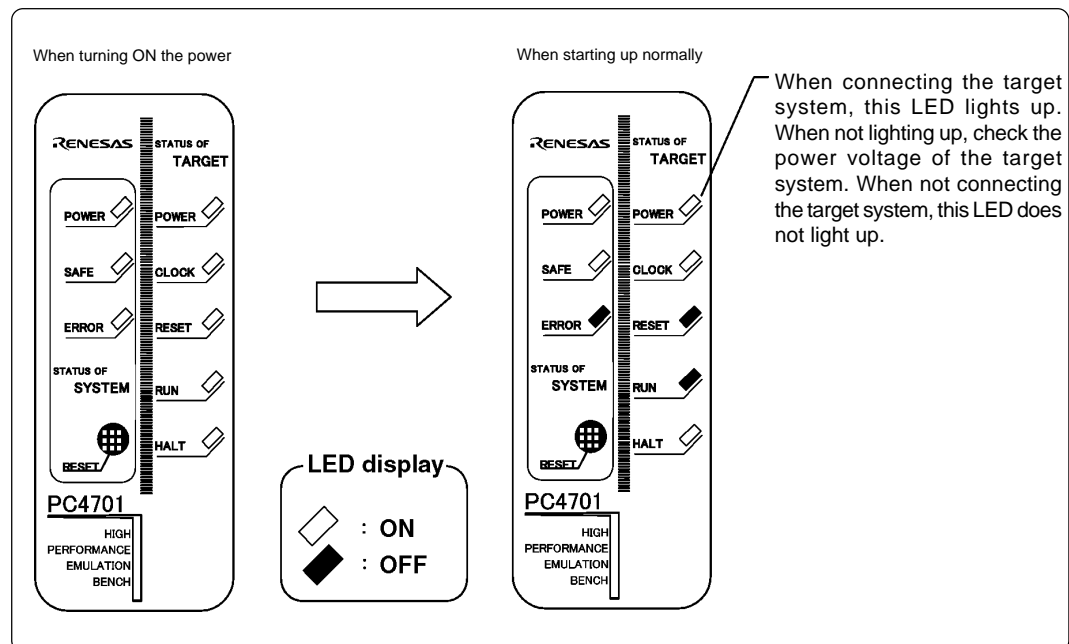

Figure 4.1 LED display when the power turned on

## 4.2 Downloading Firmware

### (1) When It is Necessary to Download Firmware

It is necessary to download firmware when:

- (1) you use this product for the first time
- (2) the firmware has been upgraded
- (3) the emulator debugger has been upgraded
- (4) you use this product with the PC4701 which was used with other emulation pod before

### (2) Downloading Firmware in Maintenance Mode

Download the firmware in maintenance mode as explained here following. The target system must not be connected when downloading the firmware.

- (1) Within 2 seconds of activating power to the emulator, press the RESET button on the emulator front panel. This will switch the emulator to maintenance mode.
- (2) Start up the emulator debugger. When the Init dialog box setup is completed, the dialog which urges to download the firmware will appear. Download the firmware following messages. Required time for downloading the firmware depends on the connection of the interface.
  - For serial interface ..... About 7 minutes
  - For parallel interface ..... About 30 seconds

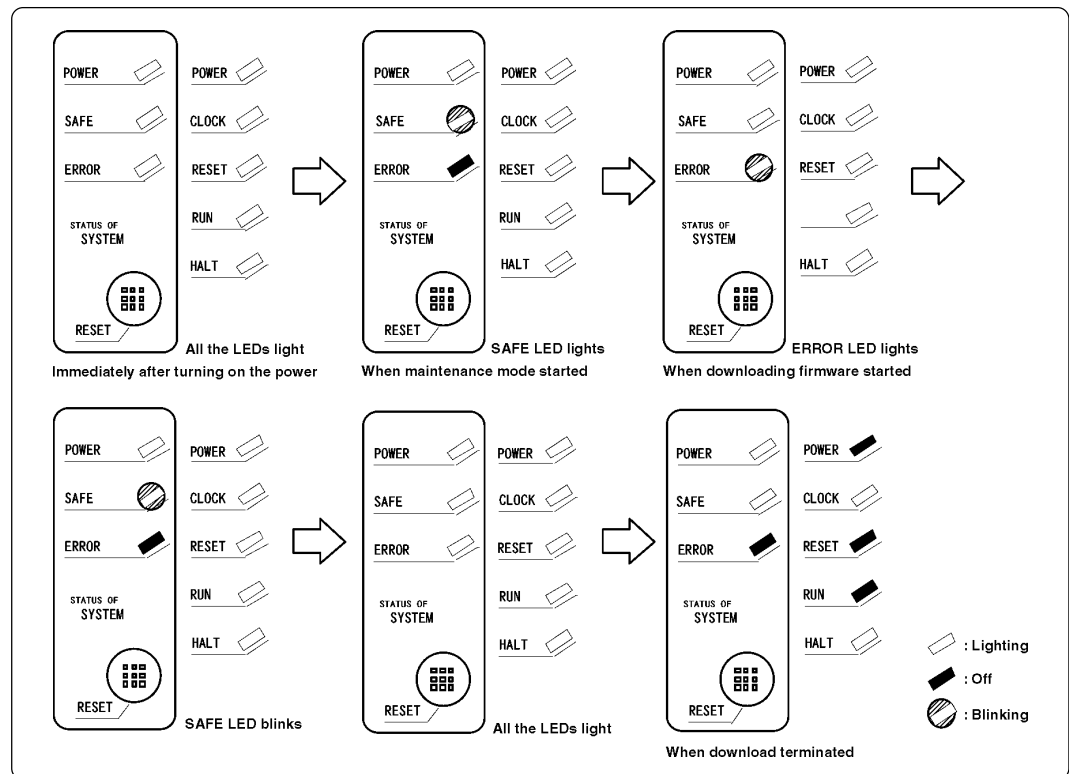

Figure 4.2 Downloading firmware in maintenance mode

## ! CAUTION

### Note on Downloading Firmware:

- Do not shut OFF power while the firmware is being downloaded. Doing so, the emulator will not start up properly. If power is shut OFF by mistake, redownload the firmware in maintenance mode.

### 4.3 Starting Up Emulator Debugger - Part 1 (Setting INIT Dialog)

The Init dialog box shown in Figure 4.3 will appear after starting up the emulator debugger. Here explains the settings in the MCU tab and Clock tab in the Init dialog box. The dialog box shown below is an example of the emulator debugger M3T-PD77 V.4.00 Release 1. For more details, refer to M3T-PD77 User's Manual.

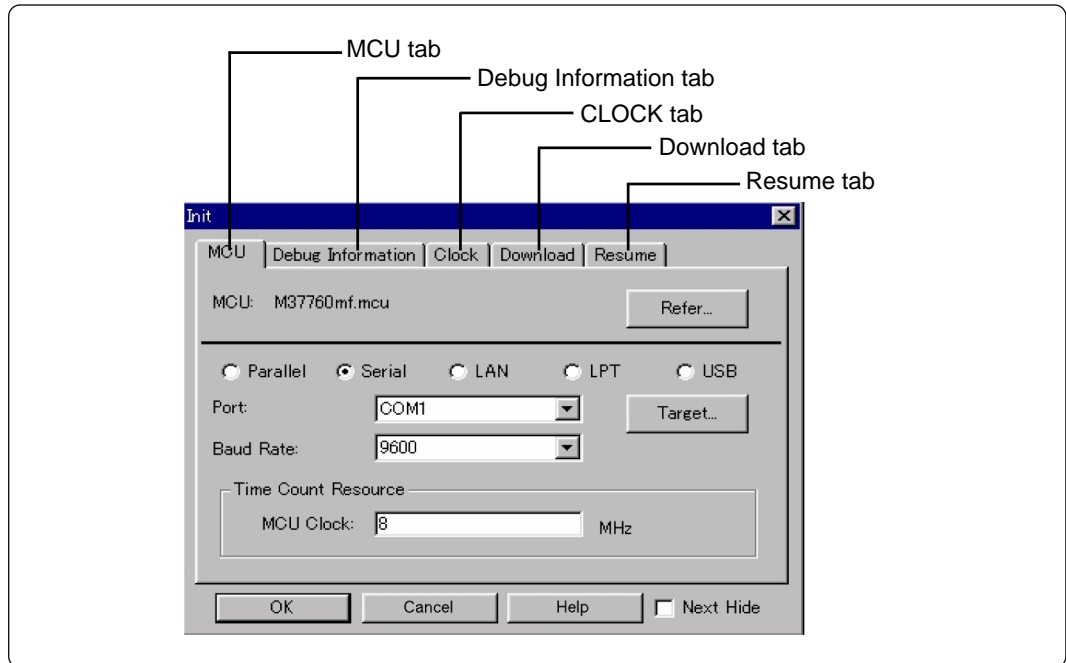

Figure 4.3 INIT dialog display

#### (1) Setting MCU Tab

This image provides a detailed view of the 'MCU' tab in the 'Init' dialog box, with callouts explaining the settings:

- MCU file:** To debug 7760 Group 7760/7762/776A MCUs, choose the "M37760mf.mcu" file.
- Communications interfaces:** Choose an interface you use. In this example the serial interface is chosen.
- Clock frequency:** Specify the operation clock of the target MCU considering the frequency division ratio of the clock.  
 Example: When the supplied clock is 16 MHz and the MCU operates divide-by-two: Set "8" MHz.

## (2) Setting CLOCK Tab

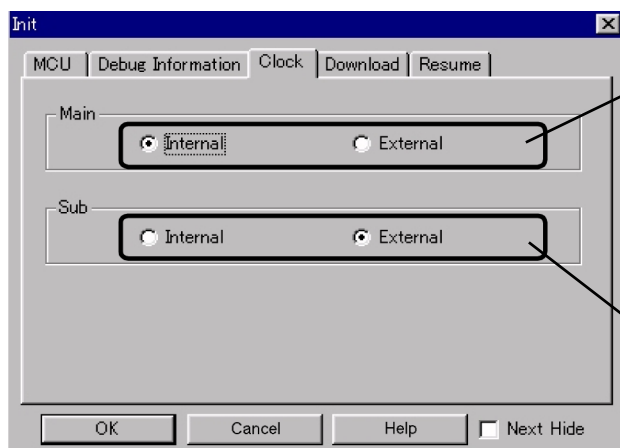

Make the settings of the clock supply.

### Main

Choose the clock supply for XIN pin.  
INTERNAL: Supplied from the oscillator circuit board of the emulation pod

EXTERNAL: Supplied from the oscillator circuit of the target system

### Sub

Choose the clock supply for XCIN pin.  
Read the precaution below.

INTERNAL: Supplied from the oscillator circuit (32.768 kHz) of the emulation pod

EXTERNAL: Supplied from the oscillator circuit of the target system

## CAUTION

### Note on Setting XCIN Pin:

- When using P31/XCIN pin as a sub-clock, set the SW1 switch to the "XCIN" side. For details on the switch settings of the emulation pod, see "3.2 Switch Settings" (page 23).

## 4.4 Starting Up Emulator Debugger - Part 2 (Setting EMEM Dialog)

The EMEM dialog box will appear after the settings in the Init dialog box by starting up the emulator debugger or downloading the firmware. Here explains how to set the processor mode of the target MCU, allocate the emulation memory and set the debug monitor area. The dialog box shown below is an example of the emulator debugger M3T-PD77 V.4.00 Release 1. The display and setup items may vary according to the version of the M3T-PD77. For more details, refer to M3T-PD77 User's Manual.

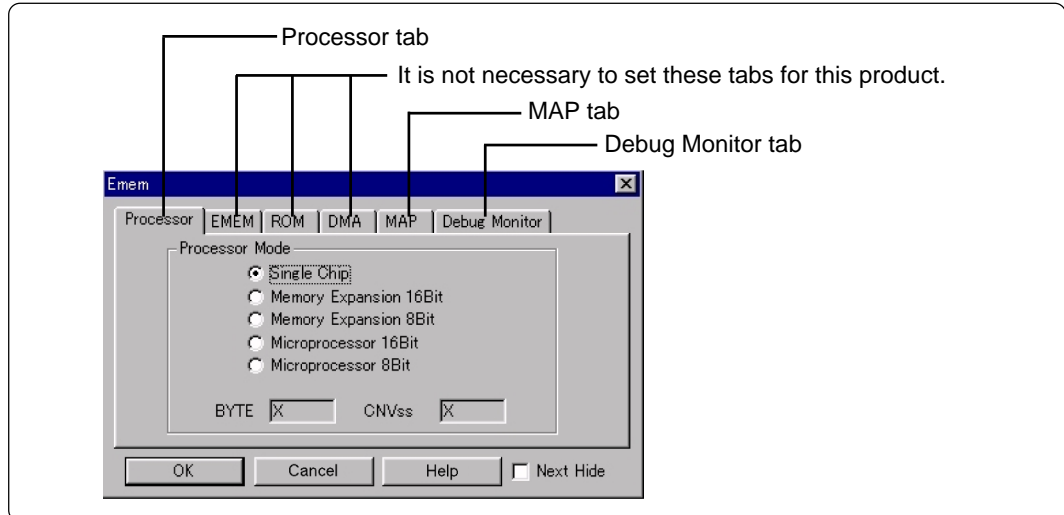
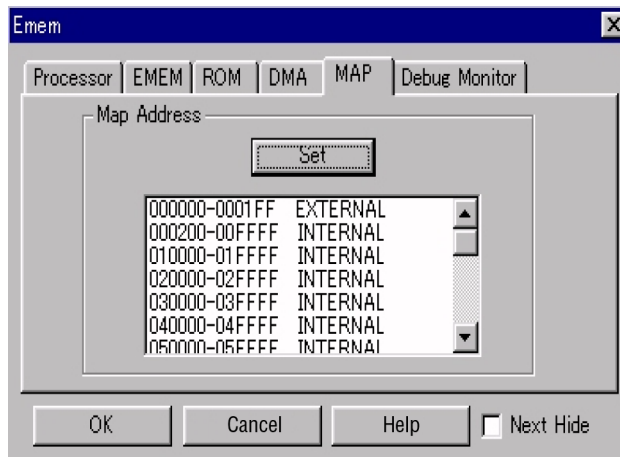

Figure 4.4 Emem dialog display

### (1) Setting Processor Mode Tab

Be sure to use single-chip mode as a processor mode.

### (2) Setting MAP Tab



Choose the "M37760mf.mcu" file for M37760 Group MCUs.

## CAUTION

### Notes on Emulation Memory Settings:

- Set the SFR area (000000<sub>16</sub> - 0001FF<sub>16</sub>) to EXTERNAL.
- Set internal RAM area (001000<sub>16</sub> - 001BFF<sub>16</sub>) to INTERNAL.

### (3) Setting Debug Monitor Tab

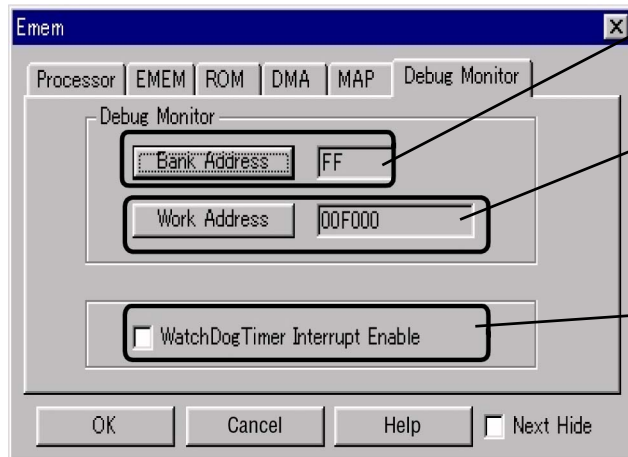

Debug bank memory:  
Set "FF" and, with this product, do not change this setting.

Monitor work area:  
Specify an area which can be read and written into in the 0 bank. The specified address is used as a work area, and you can not use this address.

Watch dog timer:  
Cancel the watchdog timer for normal debug operations.

#### Settings

- : Disabled (Watch dog timer prohibited)
- : Enabled (Watch dog timer allowed)

## CAUTION

### Note on Monitor Work Area:

- Be sure to specify an area which can be read and written into as a monitor area. In the monitor area 6 bytes of operation codes used in the emulator system are stored. If these operation codes are rewritten, the emulator system will not work properly. Therefore, do not access the monitor work area.

## CAUTION

### Note on Debug Bank Memory Area:

- In the debug bank memory area data used for the emulator system is stored. If the data is rewritten, the emulator system will not work properly. Therefore, do not access the debug bank memory.

## CAUTION

### Note on Watchdog Timer:

- When the watchdog timer is enabled, you can execute free run only.

## 4.5 Self-check

### (1) Self-check Procedure

To run the emulator self-check, do so as explained here below. While self-checks are in progress, LEDs will change as shown in Figure 4.5.

- (1) Set the switches in the emulation pod same as the factory setting (see "Table 3.1 Switch settings of the M37760T-RPD-E" on page 24).
- (2) When the target system is connected, disconnect the target system.
- (3) Within 2 seconds of activating power to the emulator, press the RESET button on the emulator front panel to switch the emulator to the maintenance mode.
- (4) Check the "SAFE" LED starts flashing and then press the RESET button again.
- (5) The self-checks will start. If the normal result is displayed in about 2 minutes, the self-check has terminated normally.

### (2) If an Error is Detected in the Self-check

If the self-check does not result normally (ERROR 1 or ERROR 2 in Figure 4.5), check the following.

- Check the connection of the emulation pod and the PC4701.
- Redownload the proper firmware.
- Check if the switches in this product is set same as the factory-setting (see "3.2 Switch Settings" on page 23).

## CAUTION

### Note on the Self-check:

- If the self-check does not result normally (excluding target system errors), the emulation pod may be damaged. Contact your local distributor.



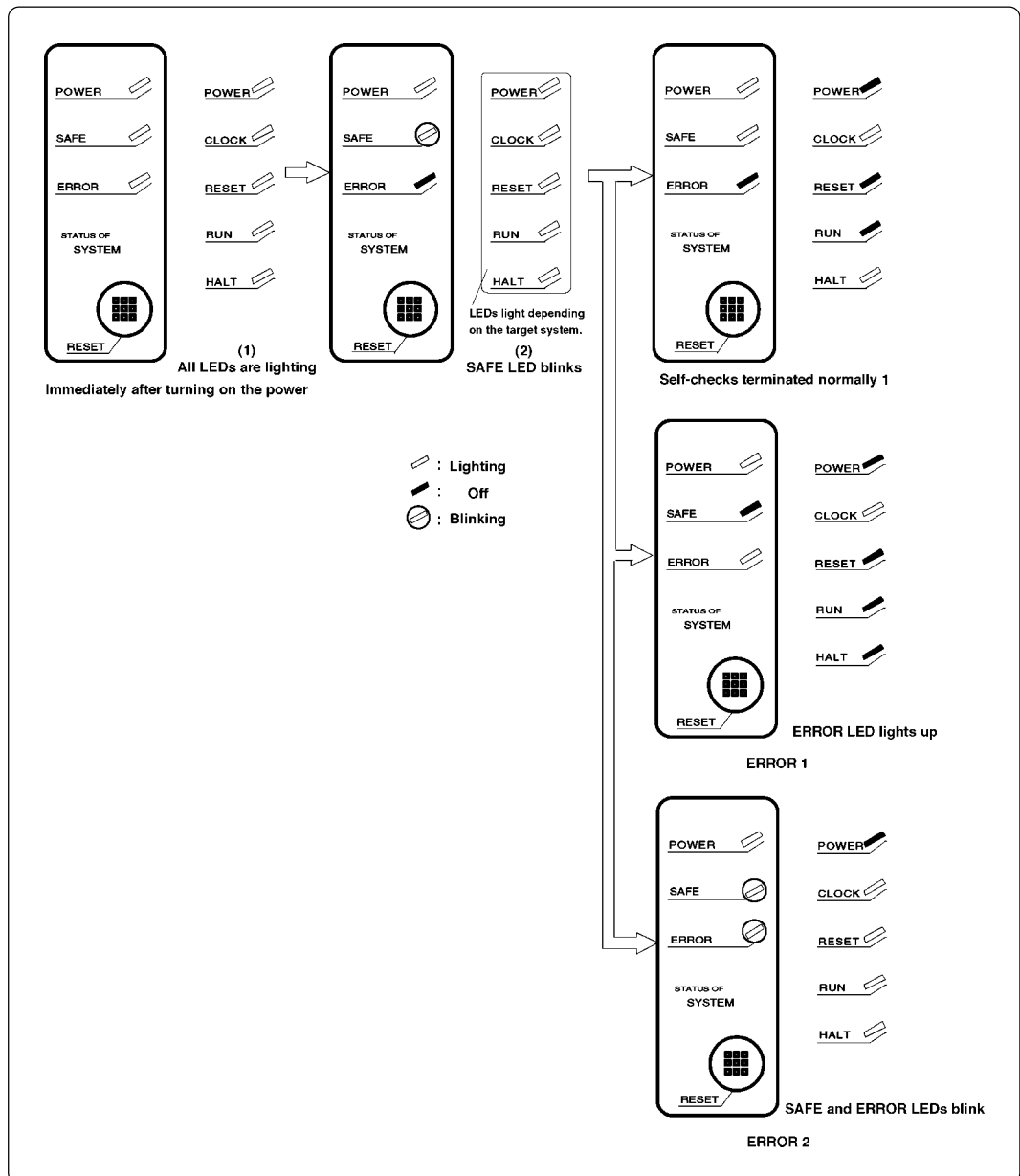

Figure 4.5 Self-check procedure

# MEMO

# Chapter 5. Specifications

This chapter describes specifications of this product.

5.1 Specifications .....	44
5.2 Memory Mapping .....	45
5.3 Connection Diagram .....	46
5.4 External Dimensions .....	50
(1) External Dimensions of the Emulation Pod .....	50
(2) External Dimensions of the Converter Board .....	51

# Chapter 5. Specifications

## 5.1 Specifications

Table 5.1 lists the specifications of the M37760T-RPD-E.

*Table 5.1 M37760T-RPD-E specifications*

Emulator	PC4701	
Applicable MCUs	7760 Group 7760: M37760M8, M37760MC, M37760MF, M37760FF, M37760EF 7760 Group 7762: M37762M8, M37762MC, M37762MF 7760 Group 776A: M3776AM8, M3776AMF	
Evaluation MCU	M37760FFH-TOOL	
Power voltage	XIN = 12 MHz, double-speed mode: 4.0 to 5.5 V XIN = 16 MHz, high-speed mode: 4.0 to 5.5 V XCIN = 32.768 kHz, low-speed mode: 2.6 to 5.5 V	
Usable mode	Single-chip mode	
Emulation memory	Fixed 256 KB (banks 00 - 03 fixed)	
Maximum operating frequency	VCC = 4.0 to 5.5 V: XIN = 12 MHz double-speed mode ( $\varnothing$ = 12 MHz) VCC = 2.6 to 5.5 V: XCIN = 32.768 kHz low-speed mode	
Clock supply	XIN-XOUT	Internal oscillator circuit board (OSC-3: 16 MHz) Switchable to external oscillator input
	OSCIN3	Internal oscillator circuit board (OSC-3: 14.318 MHz)
	XCIN-XCOUT	32.768 kHz (mounted in the emulation pod) Switchable to external oscillator input
Power supply to emulation pod	1. Supplied from an emulator. 2. The operating voltage of the emulation pod is determined by detecting the supply voltage of the target system. When no target system is connected, or when the supply voltage of the target system is more than 5.0 V, the operating voltage is 5.0 V.	
Connection to target system	Refer to "3.5 Connecting the Target System" (page 31).	
Operating temperature	5 to 35°C (no dew)	
Storage temperature	-10 to 60°C (no dew)	
International standards	<ul style="list-style-type: none"> <li>• U.S. EMI standards (FCC part 15 Class A)</li> <li>• CE marking (EN55022, EN55024)</li> </ul>	

## 5.2 Memory Mapping

Figure 5.1 shows memory map when using PC4701 emulator.

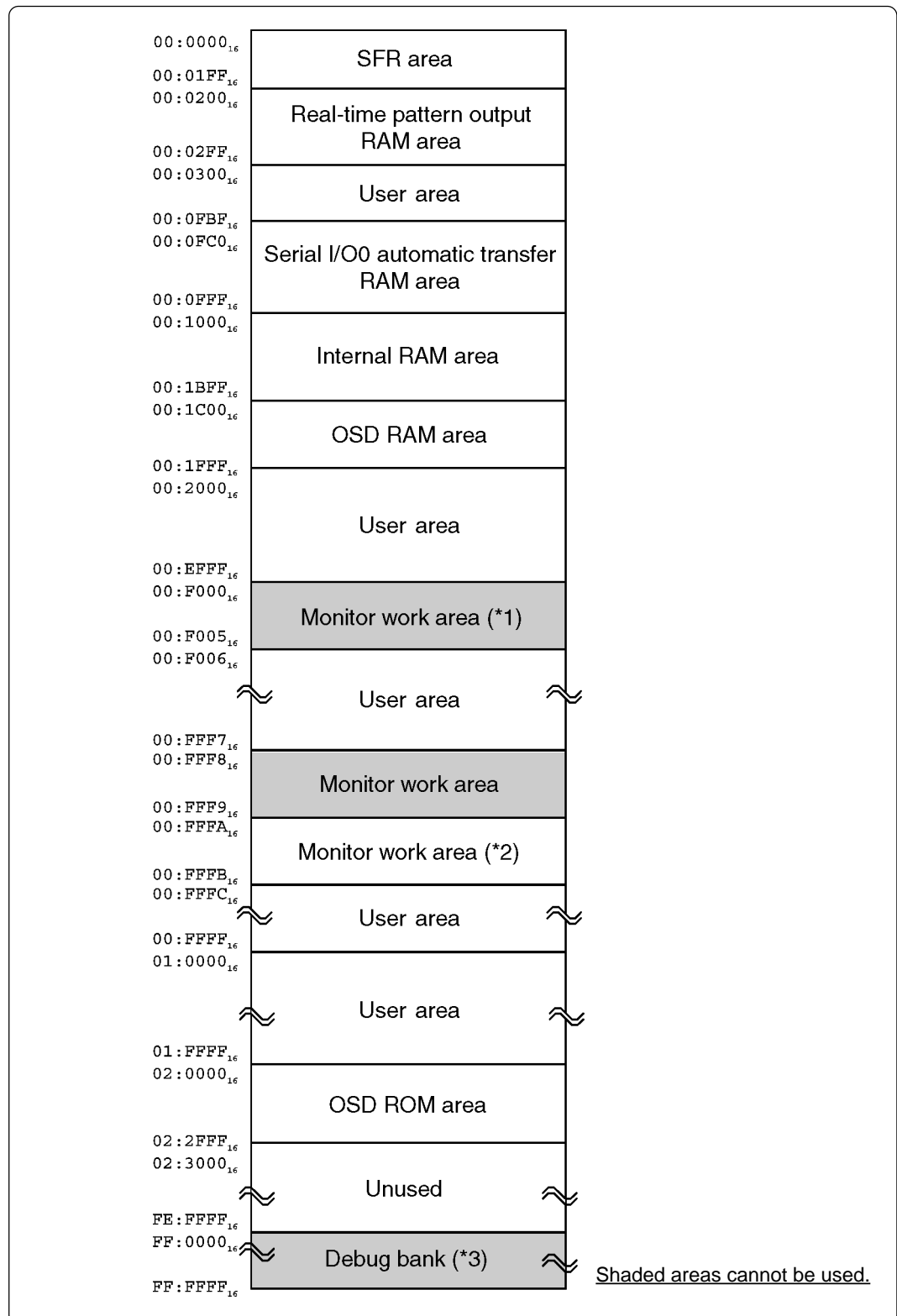

Figure 5.1 Memory map when using PC4701 emulator

\*1 This is the initial setting. This area can be moved within 0 bank.

\*2 This area can be used only when the step and the software break are not used.

\*3 For this product, fix to bank FF.

## 5.3 Connection Diagram

Figures 5.2 through 5.5 show the connection diagrams of the M37760T-RPD-E.

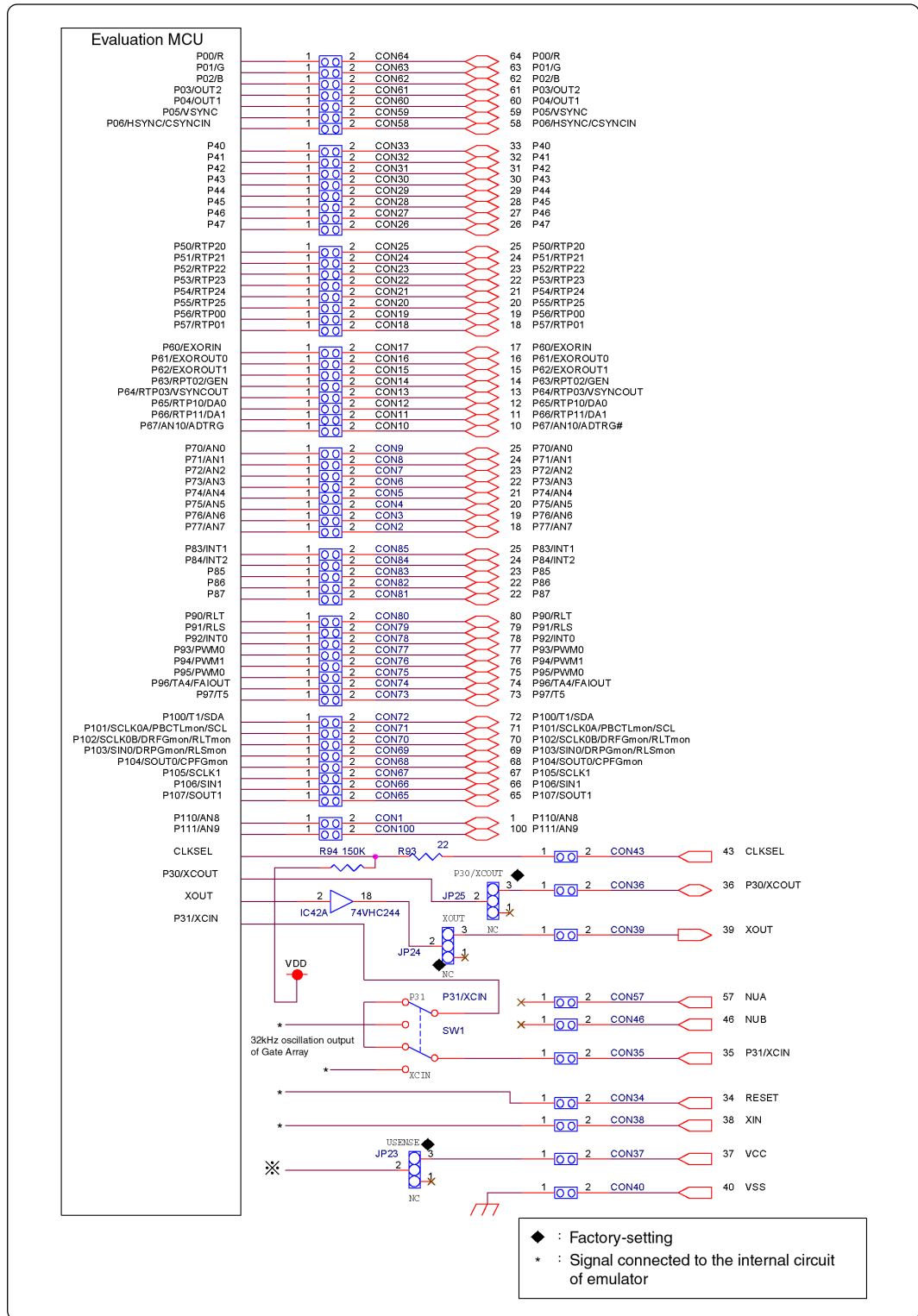

Figure 5.2 Connection diagram 1/4

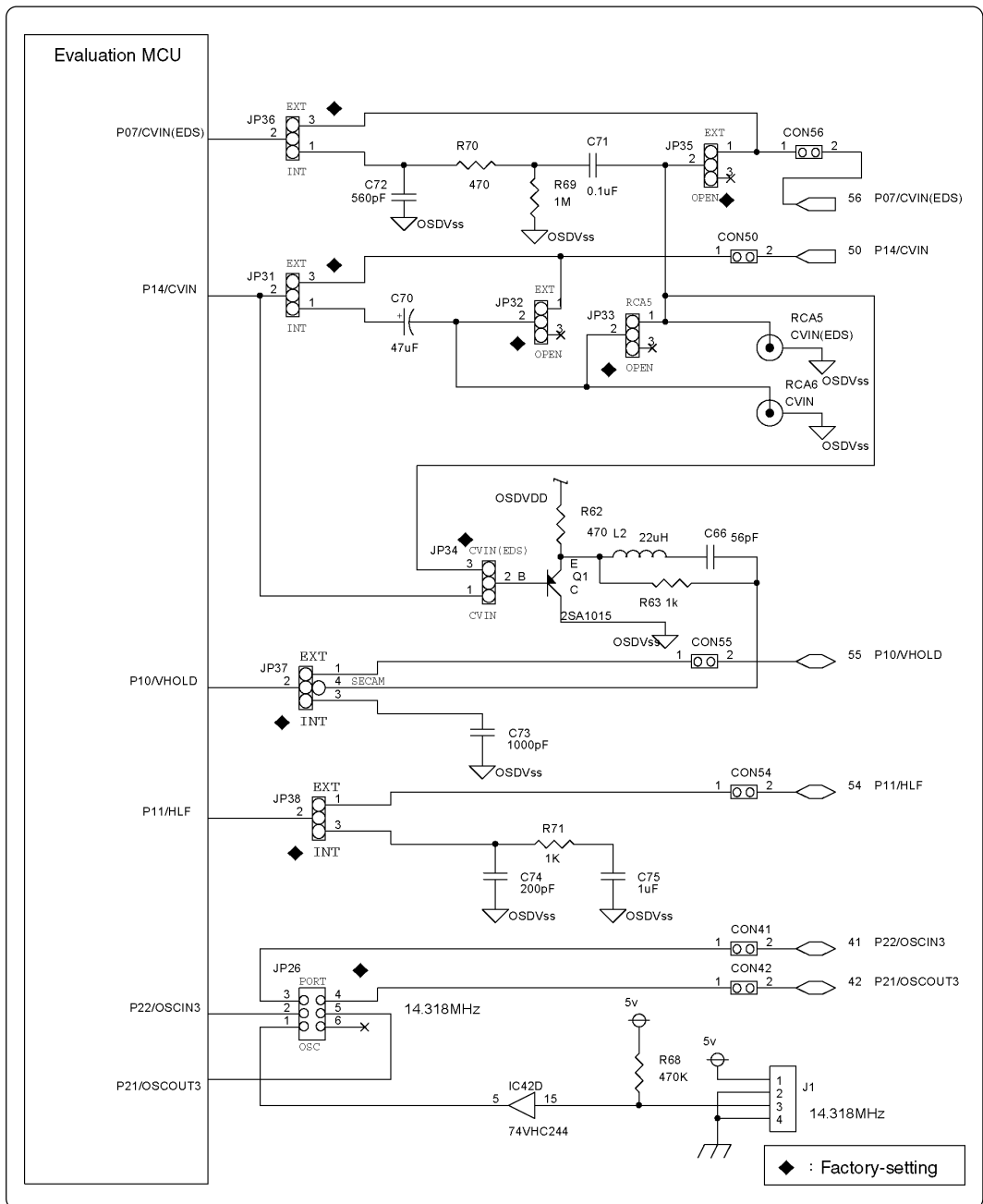

Figure 5.3 Connection diagram 2/4

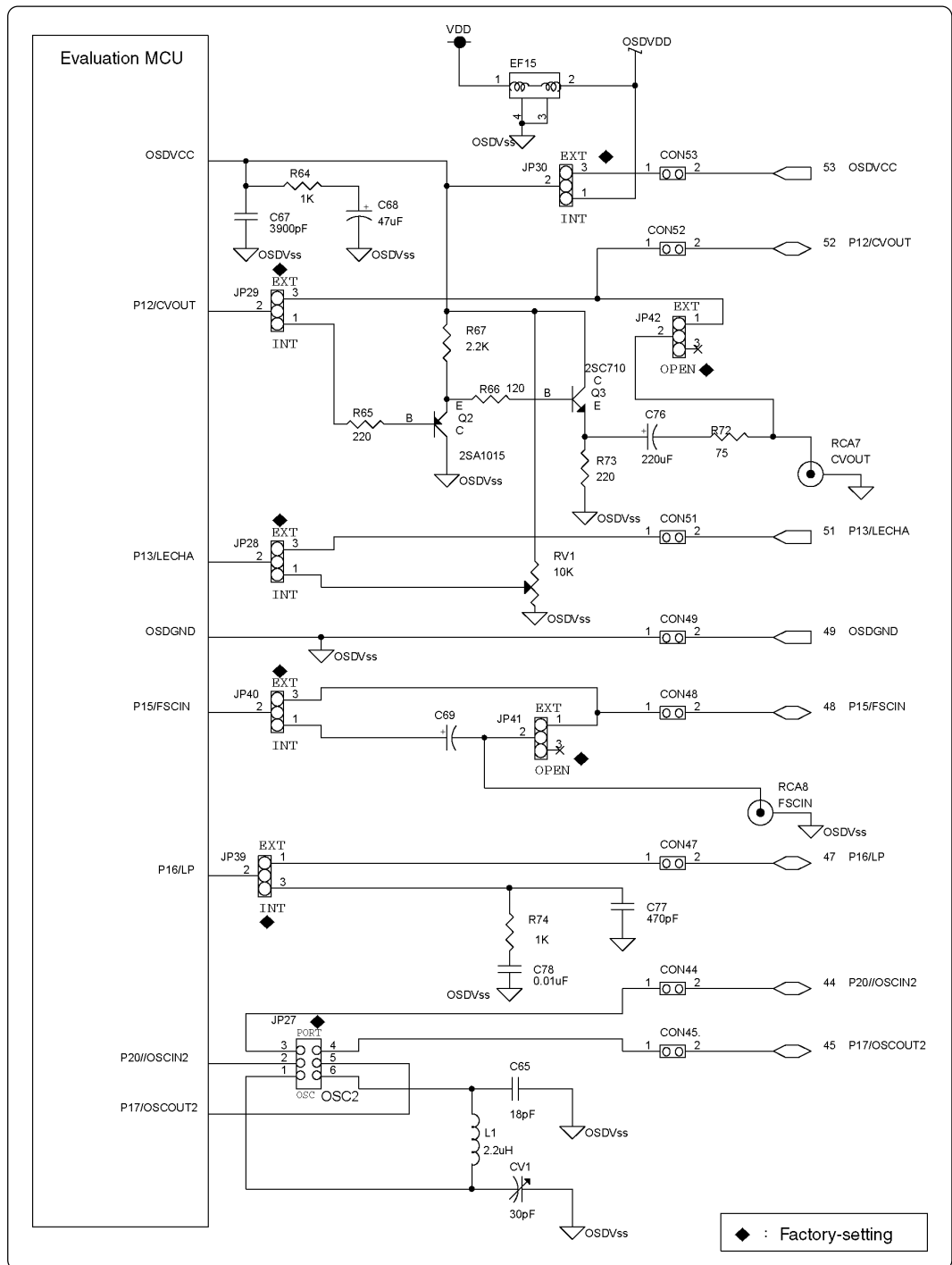

Figure 5.4 Connection diagram 3/4



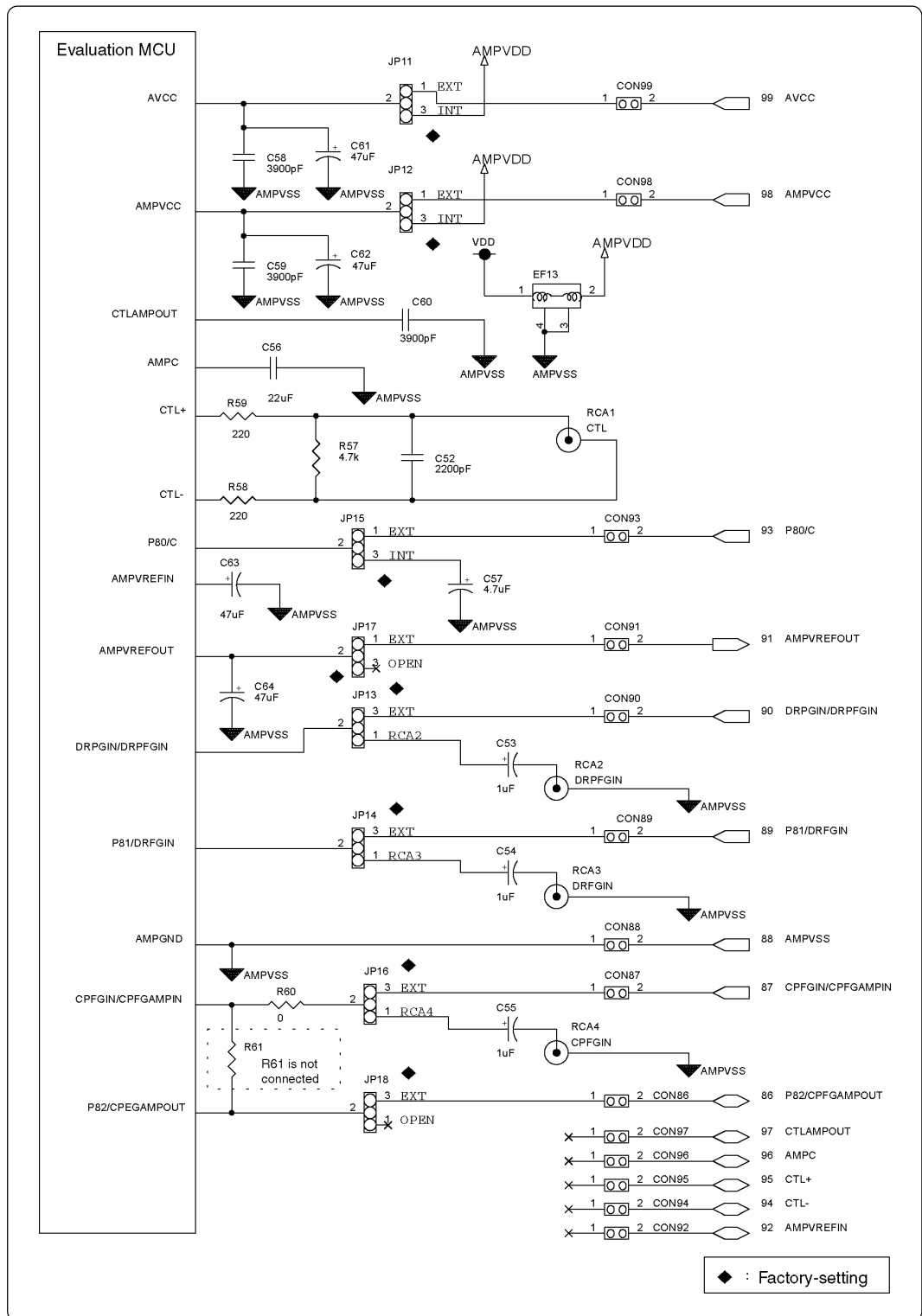

Figure 5.5 Connection diagram 4/4

## 5.4 External Dimensions

### (1) External Dimensions of the Emulation Pod

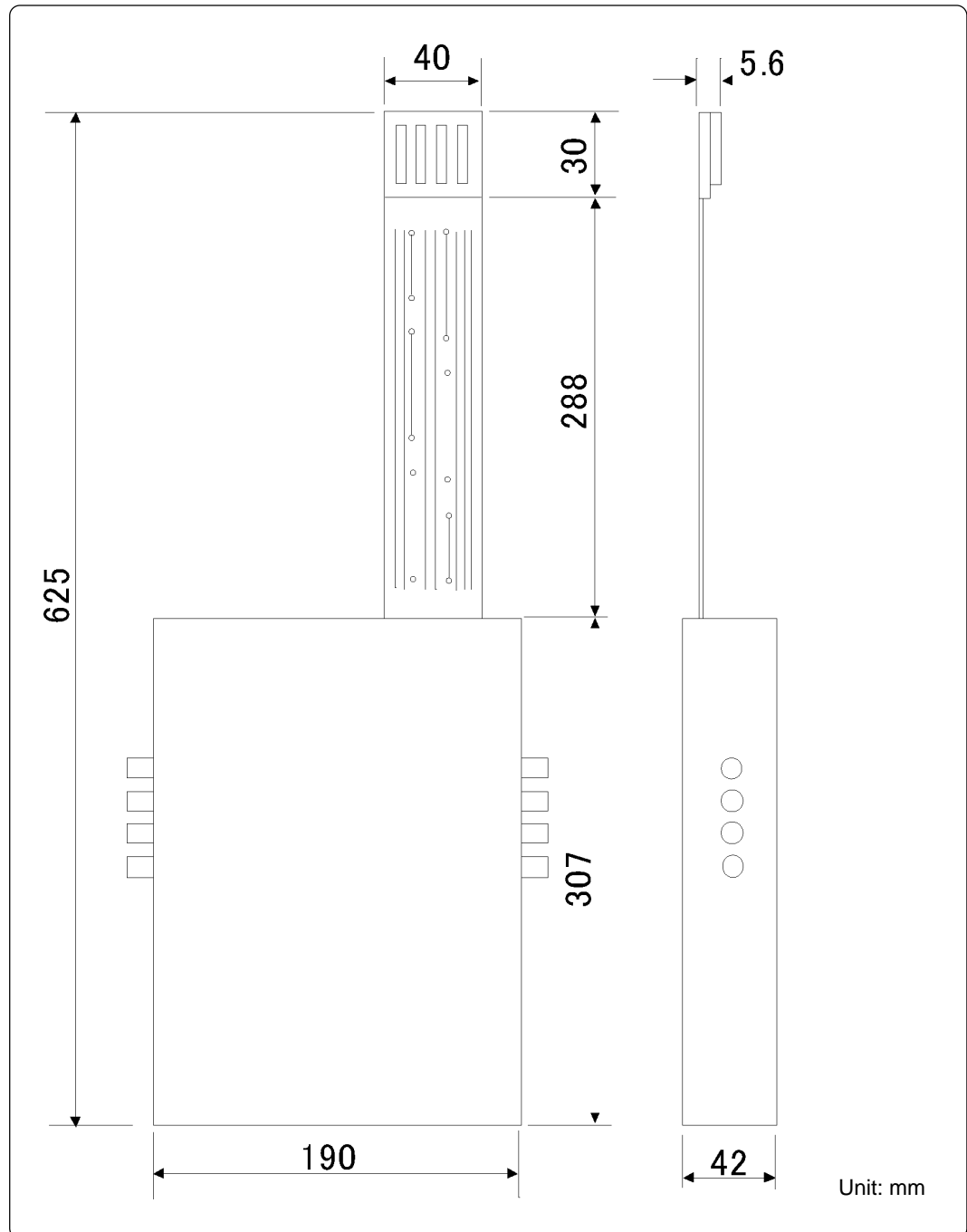
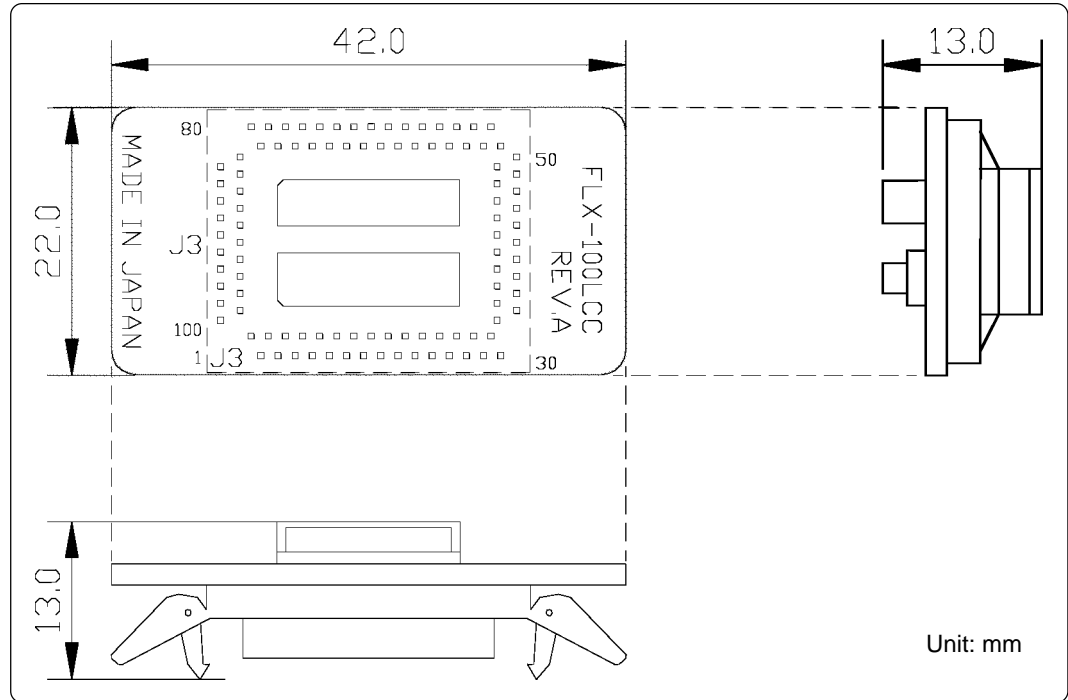

Figure 5.6 External dimensions of the emulation pod

**(2) External Dimensions of the Converter Board**



*Figure 5.7 External dimensions of the M3T-FLX-100LCC*

# MEMO

# Chapter 6. Troubleshooting

This chapter describes how to troubleshoot when this product does not work properly.

6.1 Troubleshooting up to Emulator Debugger Startup .....	54
(1) Errors Displayed over the Emem Dialog Box and Remedial Action .....	55
6.2 When the M37760T-RPD-E Does Not Work Properly .....	56
6.3 How to Request for Support .....	57

# Chapter 6. Troubleshooting

When this product does not work properly, check the following.

## 6.1 Troubleshooting up to Emulator Debugger Startup

Figure 6.1 explains troubleshooting from when power to the emulator is activated until M3T-PD77 starts up (until the Program window opens up). If trouble occurs while the target system is connected, disconnect the target system and check operation in order to quickly identify the cause.

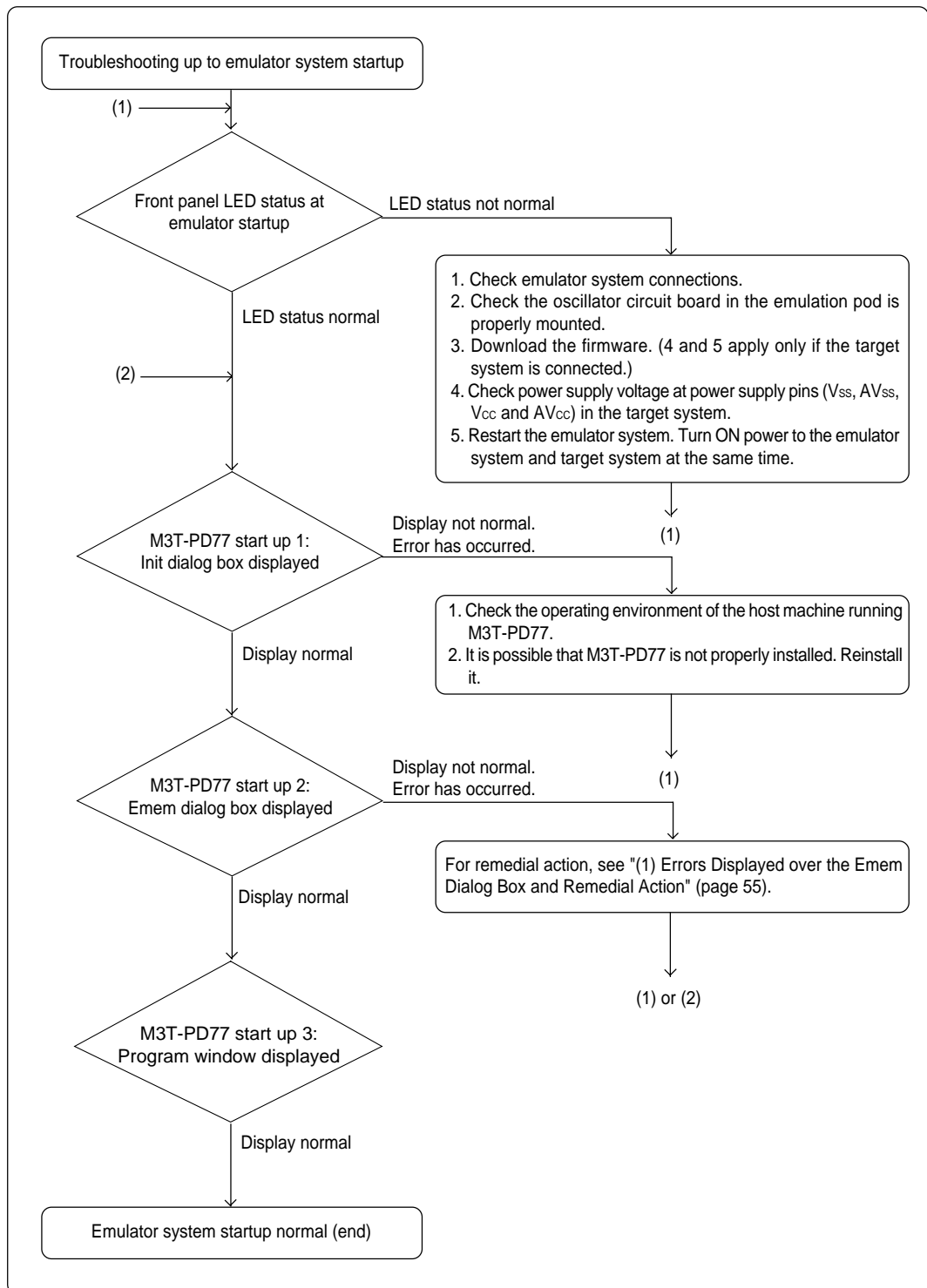

Figure 6.1 Troubleshooting when the emulator debugger starts up

### (1) Errors Displayed over the Emem Dialog Box and Remedial Action

Error Code	Error Message	Cause and Remedial Action
11503	Inconsistency between the processor mode and target system. Debugging will proceed in the XXXX mode.	The setting of the processor mode is wrong. >> Check the processor mode in the Emem dialog box is set to single-chip mode.
1704	Not connected to target.	Communications between the emulator and target system are not normal. >> Check the connection between the emulator and host machine. >> Check the interface selection switch on the emulator rear panel. >> Check the interface setup on the Init dialog box.
1705	Cannot connect to target.	
1713	Communication error. Cannot send data to target.	
1714	Communication error. Cannot receive data from target.	
11457	Target system is not properly configured.	Emulator system connections are not correct. >> Check emulator system connections.
11465	Cannot reset target MCU from the software. Reset target system.	<p><b>When target system is not connected:</b> After the emulator sent the reset request to the MCU, the MCU did not function properly. &gt;&gt; Check the Main field under the Clock tab (Init dialog box) is set to INTERNAL.</p> <p><b>When target system is connected:</b> &gt;&gt; The RESET* pin of the target system may be active ("L"). Check RESET* pin status. &gt;&gt; If not using the oscillator circuit of the target system, check the Main field under the Clock tab (Init dialog box) is set to INTERNAL. &gt;&gt; If using the oscillator circuit of the target system and the Main field under the Clock tab (Init dialog box) is set to EXTERNAL, check whether the oscillator circuit of the target system is oscillating properly.</p>

## 6.2 When the M37760T-RPD-E Does Not Work Properly

Check the following items when the M37760T-RPD-E does not work properly. Go to (1) when your M37760T-RPD-E is connected to the target system, and go to (2) when not connected.

### (1) YES, connected.

- Check whether the PC4701 and M37760T-RPD-E are connected properly via the 120-pin flexible cable. For the connection, refer to "3.4 Connecting the PC4701" (page 29).
- Check whether the switches of the emulation pod are properly set. For the switch settings, refer to "3.2 Switch Settings" (page 23).
- Check MCU operation mode is set to single-chip mode.
- Check the MCU file is properly set. For this product, specify "M37760mf.mcu".
- Check whether the mapping information is properly set. The initial settings of map areas are as shown below.
  - 000000H to 0001FFH:   EXTERNAL
  - 000200H to 01FFFFH:   INTERNAL
- Check whether the proper oscillator circuit board is mounted according to the current operating voltage. For setting, refer to "5.1 Specifications" (page 44).
- Check whether power (within the MCU's specified range) and GND are supplied to the target system.
- If an oscillator circuit on the target system is used, check whether it is oscillating properly.
- Check whether the RESET\* pin is "H" level.

### (2) NO, not connected.

- Check whether the PC4701 and M37760T-RPD-E are connected properly via the 120-pin flexible cable. For the connection, refer to "3.4 Connecting the PC4701" (page 29).
- Check whether the switches of the emulation pod are properly set. For the switch settings, refer to "3.2 Switch Settings" (page 23).
- Check MCU operation mode is set to single-chip mode.
- Check the MCU file is properly set. For this product, specify "M37760mf.mcu".
- Check whether the mapping information is properly set. The initial settings of map areas are as shown below.
  - 000000H to 0001FFH:   EXTERNAL
  - 000200H to 01FFFFH:   INTERNAL
- Check whether the proper oscillator circuit board is mounted according to the current operating voltage. For setting, refer to "5.1 Specifications" (page 44).



## 6.3 How to Request for Support

After checking the items in "Chapter 6 Troubleshooting", fill in the text file the installer of the emulator debugger generates in the following directory and email to your local distributor.

\\SUPPORT\product name\SUPPORT.TXT

For prompt response, please specify the following information:

(1) Operating environment

- Operating voltage: X.X [V]
- Operating frequency: XX.X [MHz]
- Clock supply to the MCU: Internal oscillator/External oscillator
- Target system: Connected/Not connected

(2) Condition

- The emulator debugger starts up/does not start up
- The error is detected/not detected in the self-check
- Frequency of errors: always/frequency ( )

(3) Problem

# MEMO

# Chapter 7. Maintenance and Guarantee

This chapter describes how to maintenance, repair provisions and how to request for repair.

7.1 Maintenance .....	60
7.2 Guarantee .....	60
7.3 Repair Provisions.....	60
7.4 How to Request for Repair .....	61

# Chapter 7. Maintenance and Guarantee

## 7.1 Maintenance

If dust or dirt collects on any equipment of your emulation system, wipe it off with a dry soft cloth. Do not use thinner or other solvents because these chemicals can cause the equipment's surface coating to separate.

## 7.2 Guarantee

If your product becomes faulty within twelve months after its purchase while being used under good conditions by observing "Precautions for Safety" described in Chapter 1 of this user's manual, we will repair or replace your faulty product free of charge. Note, however, that if your product's fault is raised by any one of the following causes, we will repair it or replace it with new one with extra-charge:

- Misuse, abuse, or use under extraordinary conditions
- Unauthorized repair, remodeling, maintenance, and so on
- Inadequate user's system or misuse of it
- Fires, earthquakes, and other unexpected disasters

In the above cases, contact your local distributor. If your product is being leased, consult the leasing company or the owner.

## 7.3 Repair Provisions

### (1) Repair with extra-charge

The products elapsed more than twelve months after purchase can be repaired with extra-charge.

### (2) Replacement with extra-charge

If your product's fault falls in any of the following categories, the fault will be corrected by replacing the entire product instead of repair, or you will be advised to purchase new one, depending on the severity of the fault.

- Faulty or broken mechanical portions
- Flaw, separation, or rust in coated or plated portions
- Flaw or cracks in plastic portions
- Faults or breakage caused by improper use or unauthorized repair or modification
- Heavily damaged electric circuits due to overvoltage, overcurrent or shorting of power supply
- Cracks in the printed circuit board or burnt-down patterns
- Wide range of faults that makes replacement less expensive than repair
- Unlocatable or unidentified faults

### (3) Expiration of the repair period

When a period of twelve months elapses after the model was dropped from production, repairing products of the model may become impossible.

### (4) Transportation fees at sending your product for repair

Please send your product to us for repair at your expense.

## 7.4 How to Request for Repair

If your M37760T-RPD-E is found faulty, follow the procedure below to send your product for repair.

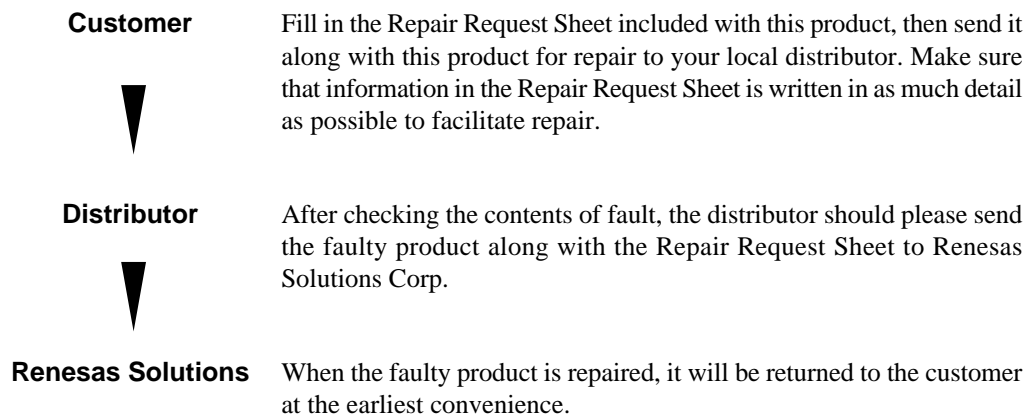

### CAUTION

#### Note on Transporting the Product:



- When sending your M37760T-RPD-E for repair, use the packing box and cushion material supplied with the M37760T-RPD-E when delivered to you and specify handling caution for it to be handled as precision equipment. If packing of your product is not complete, it may be damaged during transportation. When you pack your product in a bag, make sure to use conductive polyvinyl supplied with the M37760T-RPD-E (usually a blue bag). When you use other bags, they may cause a trouble on your product because of static electricity.

# MEMO

# M37760T-RPD-E User's Manual

---

Rev. 2.00  
March 16, 2004  
REJ10J0126-0200Z

COPYRIGHT ©2004 RENESAS TECHNOLOGY CORPORATION  
AND RENESAS SOLUTIONS CORPORATION ALL RIGHTS RESERVED



**RenesasTechnology Corp.**

2-6-2, Ote-machi, Chiyoda-ku, Tokyo, 100-0004, Japan